

midtown tulsa redux

“From atop St. John Hospital, a view of 19th Street and Utica Avenue in the 1920s.”

Tulsa Times, A Pictorial History: The Boom Years. Photographs from the Beryl Ford Collection. Text by Susan Everly-Douze.
Edited by Terrell Lester. World Publishing: 1987. Western Printing Company. Tulsa, Oklahoma.

OUUDS

The University of Oklahoma Urban Design Studio

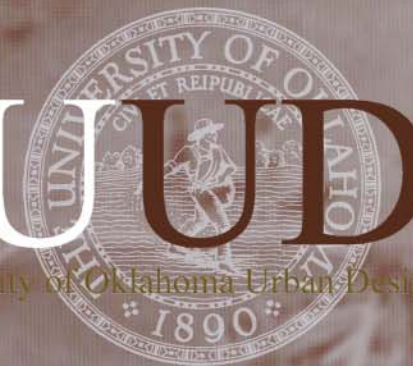

Acknowledgements

The Urban Design Studio would like to thank the following project sponsors:

The Department of Housing and Urban Development, Office of University Partnerships
The Honorable Tom Baker, District 4 Councilor, City of Tulsa
Patrick K. Treadway, Manager, Planning Division, Urban Development Department

Urban Design Studio
University of Oklahoma
College of Architecture

Project Team:

Shawn Michael Schaefer, AIA, NCARB, OUUDS Director

Yani Aller
Swaroop J. Bijjiga
Ed Sharrer
Ryon Stirling

Additional Student Support:

Marcus Fairless – Model Building

Table of Contents

Project Introduction 3-8
 Photo Survey 9-20
 Mapping 21-37
 Process 38-40
 Planning Game 41-43
 Community Workshops 44-68
 Recommendations 69-82
 Conclusion 83
 Resources 84
 Appendix 85-96

Disclaimer: “The work that provided the basis for this publication was supported by funding under Community Partnership Centers Program with the U.S. Department of Housing and Urban Development, Office of University Partnerships. The author and publisher are solely responsible for the accuracy of the statements and interpretations contained in this publication. Such interpretations do not necessarily reflect the views of the Government.”



Midtown Tulsa Redux

Introduction

The genesis of this project grew out of the Urban Design Studio's (OUUDS) Tracy Park/Gunboat Park neighborhood plan completed in 2005. That project, along with previous OUUDS projects, had established a partnership to develop community planning models for Tulsa between the Urban Design Studio, Mr. Patrick K. Treadway, Manager of Planning and Economic Development with the City of Tulsa's Public Works and Development Department, and the Honorable Tom Baker, District 4 City Councilor.

Recent conflicts in the redevelopment process in Midtown Tulsa prompted a number of members from local neighborhood associations to approach Councilor Baker to examine the dynamics of redevelopment in Midtown Tulsa. In order to study the conditions in Midtown Tulsa, a specific study area was chosen that was felt to represent a variety of Midtown-specific conditions and where numerous redevelopment projects were already occurring. It centered on the intersecting arterial streets of 15th Street and Utica Avenue and the surrounding square mile. The borders of the study area are 11th Street to the north, 21st Street to the south, Peoria Avenue to the west and Lewis Avenue to the east. The study area was intended to provide a foundation for early research while providing the prospect to apply any possible recommendations to similar Midtown Tulsa neighborhoods and commercial areas.

The four graduate students enrolled for the Midtown Tulsa Redux studio project came from a variety of backgrounds. Yani Aller, a project manager with a local architecture firm, began her UDS coursework in the summer of 2005. Swaroop J. Bijjiga came to the studio from India in the fall of 2005 and holds a bachelor's degree in Architecture. Ed Sharrer owns his own web design business and began taking classes at the UDS in the fall of 2004. Ryon Stirling joined the program in the spring of 2005 and left his teaching position to work for the university while completing his master's degree.

Unlike the Tracy Park/Gunboat Park neighborhood plan this study is not a Master Plan. This project is narrower in its scope, focusing on the process of commercial and mixed-use redevelopment along the arterial streets in Midtown Tulsa. The students attended public meetings, conducted interviews, and held community workshops to compile data relating to how the citizens of Tulsa would like redevelopment to occur adjacent to the numerous neighborhoods that define Midtown. The historic charm and character of this area is unique and different from other parts of the City and continues to draw interest from the development community. As those redevelopments take shape, it is important that they relate, sustain, and benefit the vital neighborhood environments that create this community.

Over the summer of 2005, Councilor Baker assembled a steering panel consisting of representatives from nearby neighborhood associations (Swan Lake, Yorktown, Gillette, and Lewiston Gardens), developers and business owners from the area, as well as public officials. Both hospitals in the study area, St. John and Hillcrest, were invited to participate. They sent representatives to the first steering panel meeting, but elected not to participate further. When the panel met with the students in August 2005, members suggested a representative be included from the Tulsa Preservation Commission (TPC), as well as a neighborhood representative from North Maple Ridge.

Councilor Baker described the nexus of this project as an opportunity "to study the interface between historic neighborhoods and commercial redevelopment along arterial streets in Midtown Tulsa." The August meeting brought the students and the steering panel together to produce the goals and objectives for the project and establish the work schedule. Generally, the fall semester was divided into two sections, with the first focused on research and the second dedicated to developing and producing an urban planning game to be used during community workshops. The spring semester was also split into two sections, the first hosting the community workshops and the second devoted to compiling all research data and producing the final study document.



The student team standing on Cherry Street. Pictured, left to right: Ed Sharrer, Swaroop J. Bijjiga, Yani Aller, Ryon Stirling.

Project Schedule

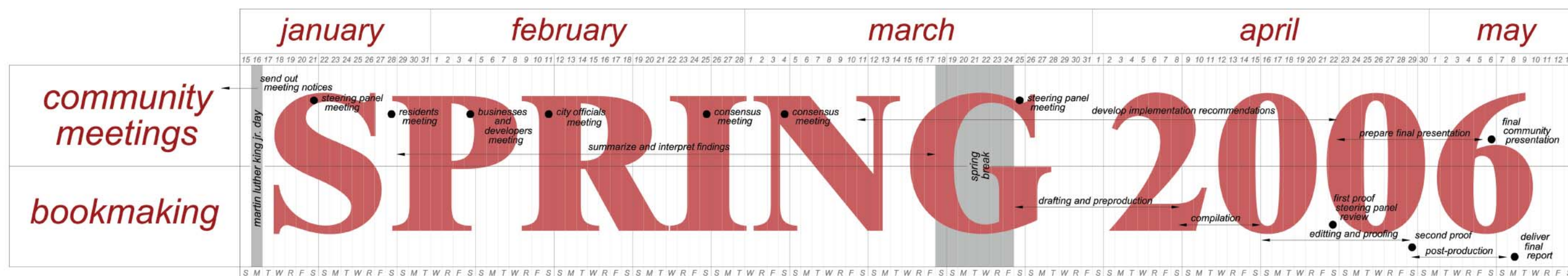
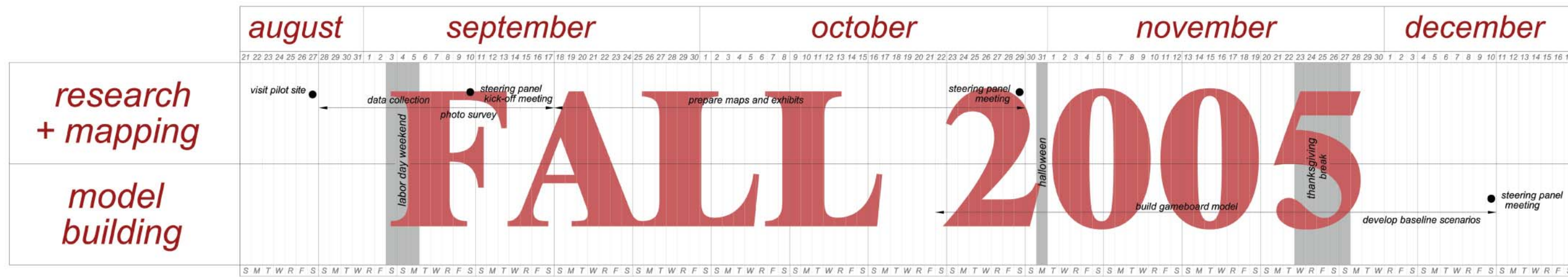

Midtown Tulsa Redux

Steering Panel

A steering panel consisting of neighborhood leaders, business owners, real estate developers and city officials was created to provide history and data for the study, to assist in organizing meetings and other communications and to ensure different perspectives are included and listened to in the project. The steering panel did not decide substantive issues concerning the project nor did it decide or edit the content of the project's findings which is solely the work of the University of Oklahoma Urban Design Studio. The steering panel met approximately once per month to review the project's progress and plan future activities.



Members of the Steering Panel discuss the goals and objectives of the project.

Chris Bumgarner
Real Estate Developer

John Bumgarner
Real Estate Developer

Chip Atkins
Swan Lake Representative

Dusty Peck
Swan Lake Representative

Susan McKee
Yorktown Representative

Mark Radzinski
Yorktown Representative

Carol Lambert
Lewiston Gardens Representative

Janice Nicklas
Maple Ridge Representative

Bruce Bolzle
Real Estate Developer

Shawn Michael Schaefer
Urban Design Studio

The Honorable Tom Baker
District 4 City Councilor

Patrick K. Treadway
Urban Development Department

Stacey Bayles
Planning Commission

Jim Turner
Tulsa Preservation Commission

Kathy Glover
Cherry Street Merchants Association

Goals and Objectives

- Examine the interface between historic neighborhoods and commercial redevelopment along arterial streets in Midtown Tulsa.
- Bring together divergent groups in the city development process to increase dialogue, share ideas, build trust and identify problems.
- Study a pilot area centered on 15th Street and Utica Avenue to better understand the development patterns, physical constraints and community characteristics of the issue.
- Conduct workshops to discover how to make redevelopment better, create a clear vision and foster consensus.
- Examine the current development and regulatory process and possibly recommend reforms to planning and zoning methods, public policy and private development practices.
- Develop a model which might benefit the city as a whole by suggesting a new development pattern incorporating the concerns of citizens, developers, and city officials.

Members of the steering panel and the project team met on September 10, 2005 to formulate the goals and objectives for the project. Each member was asked to state their goals and opinions. The list to the left is an attempt to summarize the extensive conversation that occurred.



Project team members Ryon Stirling (seated) and Ed Sharrer work with the steering panel.



Neighborhood Map

Vicinity Map



The pilot study area is located in the Midtown region of Tulsa one mile southeast of downtown.

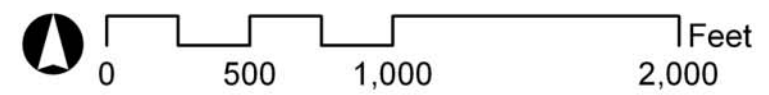

Neighborhood base map data provided by the City of Tulsa Department of Public Works, Engineering Graphic Division and created by the Urban Design Studio.



Midtown Tulsa Redux

Methodology

Research Process

To better appreciate the development process, the students attended numerous public meetings including the City Council, Tulsa Metropolitan Planning Commission, Board of Adjustment, Tulsa Preservation Commission (TPC), Midtown Coalition of Neighborhoods, Lewiston Garden Neighborhood Association/ Indian Nation Council of Government (INCOG) public meeting, Tulsa Utility Authority, and the City of Tulsa, Technical Advisory Committee. They conducted interviews with staff from INCOG (Dane Matthews and Delise Tomlinson), Public Works (Paul Zachary), TPC (Jim Turner), a neighborhood association president (Carol Lambert), commercial developers (John and Chris Bumgarner), and a residential developer (Amanda Daily). These interviews offered insights and raised awareness of the perceptions and realities that exist regarding the development process in Tulsa.

Photo Survey

The initial research continued by walking through the study area to survey the existing urban conditions. The study area was then photographed, documenting the conditions found at intersections, commercial-residential transitions, arterial streetscapes, and typical homes in the neighborhoods. Panoramic shots were taken at major intersections to compare commercial development patterns, building heights, and signage. Photos that led to further inquiries included those that showed the transitions between commercial and residential development, paying close attention to parking areas, landscape buffers, service entrances, and screening walls. From the photos taken along the arterial streets, the students could identify that the majority of uses are commercial in nature; though they had not always been, evidenced by the conversion of single-family homes into businesses. This photo survey depicts the present conditions in the study area and the pattern of development.

Mapping Inventory

The students also incorporated newly learned Geographic Information System (GIS) skills and created various maps in ArcInfo to describe the study area. Data was compiled from the City of Tulsa Engineering Graphics Department, university archives, U.S. Census Bureau data, INCOG, and other historical resources to create a database from which an inventory could be developed. These maps included importing a composite of Sanborn Fire Insurance maps which offered a historic view of the development patterns of a growing Tulsa from 1915 to 1926. Other maps used data from INCOG and the Tulsa Comprehensive Plan

to produce lots and blocks, land use, zoning, and special districts maps. Those maps could then be compared to the actual planning model used for the area to see how closely the development pattern followed the model. Additionally, the students analyzed U.S. Census data to compare the study area to the rest of the City of Tulsa. Multiple demographic characteristics were evaluated to offer some statistical background information. Buildings were traced from aerial photos in AutoCad and then analyzed to create a mass/void summary, parking, and pedestrian circulation maps. Also in AutoCad, contour lines at two foot intervals were linked to develop a topographical map for an awareness of drainage issues and the potential effect of the expressway.

Game Design and Model Construction

The next step was to design and construct the gaming models. It was important to create a model that was abstract in nature to represent Midtown Tulsa as a whole and avoid identifying specific properties. It had been noted that at public meetings when specific homes or developments were discussed, participants focused on their properties, instead of examining development issues and concepts.

The students designed three models built to a scale of 1:30 or where 1" equal 30'. This would allow the model to show the pattern of development (building massing, planning, and parking issues). By using a 36" by 78" door as the base for the gameboards it would provide enough space for twenty or more participants to engage in the game playing at one time. The majority of the game pieces were created from acrylic in block representations of single family homes, multi-family residential, commercial, and structured parking pieces. The latter three could be layered to create multi-story buildings. Additional pieces for the development tool-kit included markers and an eraser, push pins, round stickers, cardstock parking pieces, bass wood screening walls, a straight edge, and architectural scale. A more detailed



explanation of the game design is included in the gameplaying section of this document.

Community Workshops

Four community workshops were scheduled for the spring semester. The first three workshops served the neighborhood residents, business owners/real estate developers, and public officials, respectively, and met on consecutive Saturdays. The fourth workshop was to be a consensus meeting inviting back all of the earlier participants to learn of the areas of consensus among the three groups and play a modified version of the game to help clarify specific issues.

Analysis and Bookmaking

The last part of the project entailed compiling all the data from the development process research, photo survey, mapping inventory, game design/model construction, and community workshops together to begin organizing a portfolio that could then be proofed, reviewed, and revised to create the final Midtown Tulsa Redux document. This process included summarizing the community workshops then using that data to incorporate the earlier research into recommendations and topics for further study. Illustrations and technical drawings were completed to enhance the readers understanding by providing a graphical representation along with the text. The final document would then be available in a printed and bound 11" by 17" format and also published online in PDF format on the OUUDS website.



1420, 1418 S. Rockford



Parking lot, 14th & Rockford



1404 S. Rockford, Single family home



Arlington apartments, 1530 E. 14th Street



Looking east on the Broken Arrow Expressway service road



Oakview apartments, 14th & Rockford



Broken Arrow Expressway



Looking east from St. Louis Avenue



Tulsa Family Medicine Cntr., OU



Single family home, 1319 S. St. Louis



Single family home 1307 S. St. Louis



Apartments, NW corner, 13th & St. Louis



Single family home, S. St. Louis



Apartment, NE corner, 13th & St. Louis



Single family home, 1233 S. St. Louis



Underpass Broken Arrow Expressway, St. Louis Avenue



Looking west, 13th & Utica



Granada Apartment, 1215 S. St. Louis



Northwest Quadrant

11th Street – 15th Street, Peoria Avenue – Utica Avenue

The North West Quadrant, lies north of the Cherry Street (15th) and west of Utica Avenue. This quadrant has single family homes, mostly in the American Craftsman style and a few in the Tudor style. Some apartments are contemporary but most single owner homes date back to the 1920s. Barren streets with limited sidewalks are a common feature of this area with exceptions. This quadrant has the largest minority population with more than 30% in many blocks. There is a heavy concentration of rental housing with more than 75% of all occupied housing units for leased.



Midtown Tulsa Redux



Office conversion, 1410 S. Terrace Dr.



Donaldson Post Office, 1409 S. Terrace Dr.



1904 E. 13th St. (13th & Wheeling)



Looking west, unpaved lot, Xanthus Ave @ 12th Pl. Two homes at right are across street.



NE corner, 12th Pl. & Xanthus Ave.



Single-family homes, 1700 block of 14th Place



Vacant lot, view from 1904 E. 13th St.



SE corner, 12th Pl. & Xanthus Ave.



13th Place & Terrace Drive



N. side, parking ramp, 12th St. & Victor



Apartments, 1100 block of Victor



Single-family cottage, 1100 block, Zunis



B.A. Expwy. off-ramp (left), 14th St.



1916 E. 14th St. (visible in photo at left)



Larger homes, 14th Place (Xanthus Pl.)



Looking west, 13th Street



E. side, parking ramp, 12th St. & Wheeling



Apts. across Wheeling from ramp at left



Northeast Quadrant

11th Street – 15th Street, Utica Avenue – Lewis Avenue

The two most prominent features of the area are the Broken Arrow Expressway which cuts through the area from west to east, and several large medical buildings and parking garages of Hillcrest Medical Center. The major neighborhood “feeder” street running east-west is 13th Street, which is generous in width. There are no north-south through streets. The housing stock is primarily small, single-family bungalows in the Craftsman style, dating to the 1910s and 1920s, although there are some examples of larger, two-story homes, especially along 14th Place and also Terrace Drive. There are apartment buildings scattered throughout the area, as well as large vacant lots to the east of the medical center property.



Midtown Tulsa Redux



1544 S. Gillette Ave.



Gillette Historical Marker



1552 S. Gillette Ave.



Looking north, 1500 block, Gillette Ave.



Looking south, 17th & Yorktown



Infill on 17th



Northeast corner, 17th & Gillette Ave.



Barnard Elementary School, 2324 E. 17th



2130 E. 17th



1700 block, Wheeling Ave.



Parking ramp, 1700 block, Wheeling Ave.



1544 S. Yorktown



Looking northwest, 16th & Victor



Tree lined street in Yorktown



1551 S. Yorktown



1820 S. Yorktown



2125 E. 17th Place



1912 S. Yorktown

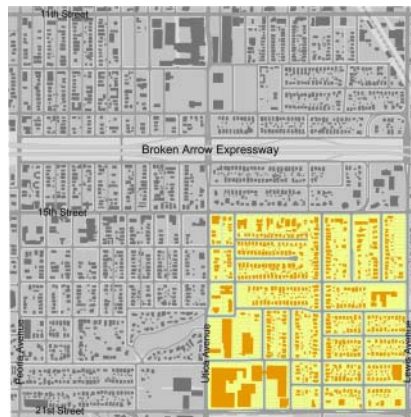

Southeast Quadrant

15th Street – 21st Street, Utica Avenue – Lewis Avenue

The Southeast Quadrant, lies just north of 21 street and east of Utica Avenue. It is comprised of mainly two historical neighborhoods: Gillette and Yorktown. Both of these neighborhoods offers a variety of housing mainly built in the 1920s-1930s. Their architectural styles include Craftsman bungalows, tudors, ranch and some recent infill homes demonstrate newer architectural trends like French Country. In addition to the single family housing, this area also includes schools and commercial along the major arterial streets. Overall, this area could be described as an active pedestrian community in which mature trees and beautiful yards create a sense of place.



Midtown Tulsa Redux



Mariman Apartments 1516 S. St. Louis



1724 S. Quaker



Apartments, 17th and Quincy



1350 E. 19th (For Rent)



Swan Lake, 1543 Swan Lake Drive



17th and Quaker, NE corner



Looking South on St. Louis



Apartments, 18th and Peoria



Swan Lake from bridge looking NE



Apartments, 17th and St. Louis



17th Pl. and Peoria



Orcutt Apartments, 16th and Quaker



1602 S. St. Louis



17th and Quaker, SW corner



Apartments, 17th and Quaker



1711 S. Quaker



Christ the King/Marquette Playground



View looking South at 16th & Quincy



Southwest Quadrant

15th Street – 21st Street, Peoria Avenue – Utica Avenue

The Southwest Quadrant, lies just south of Cherry Street (15th) and west of Utica Avenue. It is comprised of the Historic Swan Lake neighborhood, which offers a variety of housing styles including Craftsman bungalows, tudors, and foursquares. In addition to the single family housing stock, this area also includes numerous multi-family apartments. Many of the homes date back to the 1920s with some more contemporary offerings as well. The mature landscapes shaped by the tree-lined streets, abundant sidewalks, access to Cherry Street retailers and Swan Lake itself help to define this area of the city.



Midtown Tulsa Redux



Western section of Cherry Street



Stillwater National Bank, 1500 S. Utica



Eastern section of Cherry Street



Sidewalk on Cherry Street



Camerellis, 1536 E. 15th St.



Looking north on Troost Avenue



1631 E. 15th St.



Chelsea Gallery, 1639 E. 15th St.



Spot-Not Car Wash, 1511 E. 15th St.



Kilkenny's Irish Pub, 1413 E. 15th St.



St. Paul's, 1442 S. Quaker Avenue



Signage, 1413 E. 15th St.



Parking lot at 15th & Rockford Ave.



Looking east on Cherry Street



Boulevard Building



Sidewalk by Marquette School



Looking east from Marquette School

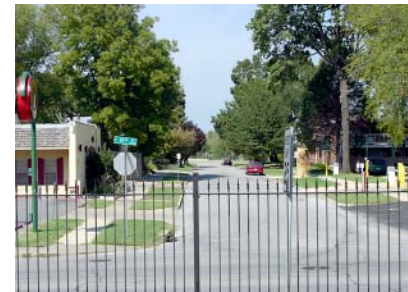

Looking North on Rockford Ave.



Cherry Street

15th Street, Peoria Avenue – Utica Avenue

The prominent features of this street are 1) Store fronts built right up to the property lines, 2) Lots filled up with the built structure, 3) On street parking for many businesses, 4) Discontinuous sidewalks, 5) Signage, parking meters, and decorative fixtures on the sidewalk 6) The width of the sidewalk is quite narrow at many places, for example by Marquette School, allowing only one or two persons to walk on it comfortably. The Cherry Street Association webpage asks us to “Stroll the sidewalks of this historic shopping district in the heart of Tulsa.” However, in most instances the sidewalks are not adequate to get a real feel of the historic shopping district.



Midtown Tulsa Redux



Council Oak Books/Dentistry, 2105 E. 15th



Law Offices, 1861 E. 15th



Center for Plastic Surgery, 1844 E. 15th



15th Street @ Victor Avenue, looking east



German Society of Tulsa, 2301 E. 15th



15th Street @ Terrace Drive, looking west



Patton Landscape Architects, 1723 E. 15th



Dermatology clinic, 1440 S. Terrace Dr.



Signage along north side of 15th St.



CT of Tulsa, 1855 E. 15th



Multi-tenant offices, 1815 E. 15th



Skin Renewal, 2118 E. 15th



Future Office Depot, SE corner 15th & Lewis



Walgreens, 1440 S. Lewis



AAA Oklahoma, 15th & Terrace Drive



Amir's Persian Imports, 2204 E. 15th



Insurance agent, 15th & Yorktown



Facials/Massage, 15th & Yorktown



15th Street Utica Avenue – Lewis Avenue

The area located between Utica Avenue and Lewis Avenue on 15th Street, is comprised of residences which have been converted into business. Generous sidewalks, mature trees and large setbacks are evidence that this area was part of a somewhat affluent neighborhood at one point. Some of the architectural characteristics reflected in this area include: Tudor, Colonial, Revival, etc. Also, a variety of newer commercial infill projects like the AAA building and the under-construction projects located on the southwest corner of 15th and Utica which will have Mediterranean characteristics exist. Another landmark is the German American Society, once a church, located on the north side of 15th Street.



Midtown Tulsa Redux



Looking North from 16th, Stillwater Nat'l



1595 S. Utica



1617 S. Utica



Empty lot on eastside-Appox. 1619 S. Utica



HealthSouth-1631 S. Utica



17th Pl. and Utica



Arvest Bank next to existing structures



Nelson's Photography studio, 1708 S. Utica



Apartments next to restaurant parking



Empty lot on westside, 17th and Utica

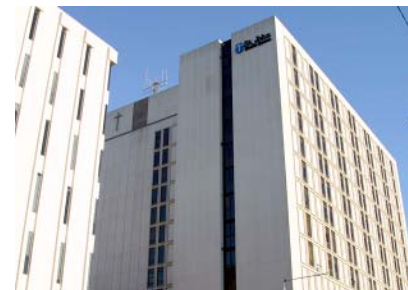

St. John from below



Utica corridor looking S. from 16th



1776 S. Utica



1756 S. Utica



Park area in front of F&M at 21st.



Parking Structure W. of Utica at 20th



Utica looking N. at 19th



Utica looking S. at 19th

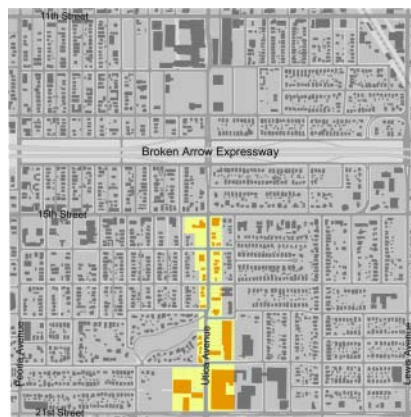

Utica Avenue

15th Street – 21st Street

The Utica Avenue corridor from 15th to 21st Street is anchored on the southern end by the St. John Medical Center complex and the F&M building and parking structure. The northern end at 15th Street, the midpoint of our study, could be described as a banking node with Stillwater National on the western corner and the recently completed Arvest on the eastern corner. In the valley between the landmarks, set homes transitioned into offices, an infill restaurant, an apartment building, and a few empty lots where homes once stood.





1430 S. Utica (west side, vacant)



1419 S. Utica (east side)



Intersection, 14th & Utica, looking north



Greenbelt, 1300 block, looking north



Medical park, 1200 block, Utica (east side)



First Lutheran Church, 13th/Utica (west side)



1435 S. Utica (east side)



Hillcrest Medical Center, 12th & Utica (west side)



1200 block, Utica, looking south. Benedict Park at left, overpass in background



SW corner, 11th & Utica, looking south



1402 S. Utica (west side, vacant)



Parking ramp, SW corner, 11th & Utica



1200 block, Utica, looking north (east side)



Two duplexes, 13th & Utica (west side)



Benedict Park, 12th & Utica (west side)



Interior of Benedict Park, west of Utica



NW corner, 15th & Utica, looking south



NE corner, 15th & Utica, looking east



Utica Avenue

11th Street – 15th Street

The Utica corridor between 11th and 15th Streets is, effectively, divided into two sections by the Broken Arrow Expressway overpass. North of the overpass is the Hillcrest Medical Center complex running along both sides of Utica with the exception of First Lutheran Church, Benedict Park, two duplexes (all on the west side of Utica) and approximately 1/2 block of greenbelt (both sides of Utica). South of the overpass, the corridor contains office uses of varying intensity (including two vacant properties) and two convenience stores on opposite corners of the intersection at 15th Street. Parking buffers of varying sizes and paving conditions separate residential and commercial properties on both sides of Utica.



Midtown Tulsa Redux



Parking lot/fence/planting on north side of 14th Pl., east of Utica Ave.



Parking lot/fence/planting on south side of 14th Pl., east of Utica Ave.



Parking lot angled to visually tie with setback of adjacent house, 1500 block Victor Ave.



Dumpster in back corner of commercial property adjacent to houses, north side of 15th St.



Parking lot entrance adjacent to 1740 Wheeling Ave.



Two-level parking garage (left) faces apartments (right) in 1200 block Wheeling Ave.



Transitions

Conditions where commercial and residential properties meet.

The above photos of transitional areas between neighborhoods and office or commercial development depict some of the current parking and zoning regulations. The regulations which are listed in the zoning code, stipulate minimum parking, screening, and landscaping requirements. It also includes limits on signage and lighting. In addition, if property happens to be a planned unit development (PUD) additional specifications may be applied. All of these factors affect both how the land is used and can create or destroy the cohesiveness of the community.



Midtown Tulsa Redux



Houses in the 1200 block of Xanthus look over an unpaved parking lot.



Four "Lincoln Plaza Parking Only" signs line the east side of Quaker, south of 15th St.



Token-required parking lot for Subway/Hideaway patrons only, 1400 block Rockford Ave.



New parking lot created between Boulevards and apartments, 1400 block Quaker Ave.



Sign on property line fence reads "More Parking 200 Feet", 1400 block Quincy Ave.



Apartments at 1515 S. Quaker with spray-painted "Private Parking" sign.



Transitions

Conditions where commercial and residential properties meet.

The perceived parking needs of retail establishments during peak operating hours as well as the requirements given in the zoning code has lead to the razing of single family homes for parking lots in our study area. Some lots are not even paved and are in violation of the current standard. The battle for parking space in front of the above apartment building, next to the old Lincoln School retail area has lead to spray painting of the brick wall in front of the building. A few of the merchants are sharing a parking lot now requiring a pass code to leave.



Midtown Tulsa Redux

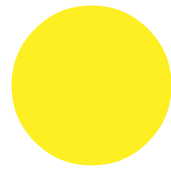

15th Street and Peoria Avenue Panoramic View

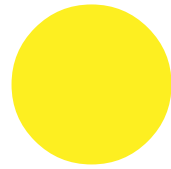

15th Street and Peoria Avenue Panoramic View

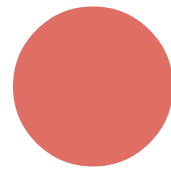

15th Street and Utica Avenue Panoramic View

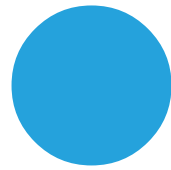

15th Street and Lewis Avenue Panoramic View

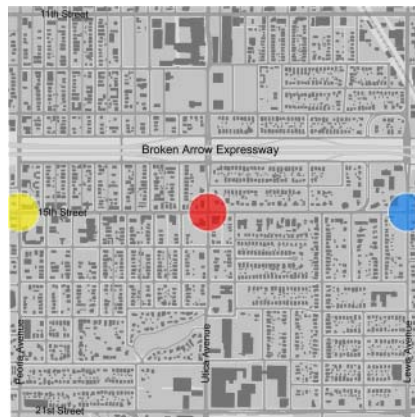

Panoramics

A view along 15th Street and its major nodes

The street scapes shown in these photographs were taken along 15th Street. Cherry Street represents a unique district in which residential, commercial, schools, and other uses occur within a few feet of each other. Because of its popularity, traffic is abundant in this area. However, unlike many similar streets in Tulsa, a sense of pedestrian life exists, providing paths which create the fabric of this district.



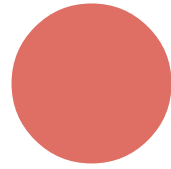

21st Street and Utica Avenue Panoramic View

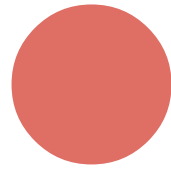

21st Street and Utica Avenue Panoramic View

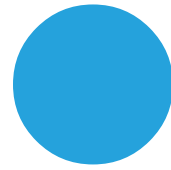

21st Street and Lewis Avenue Panoramic View

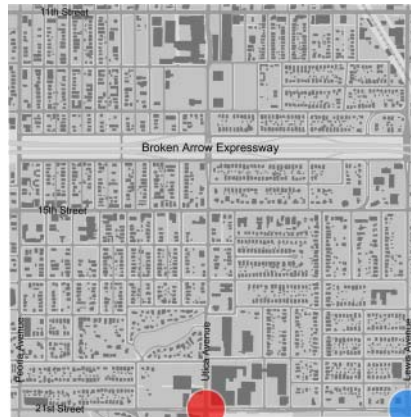

Panoramics

A view along 21th Street and its major nodes

The street panoramic views shown were taken along 21st Street. This major commercial corridor shows examples of myriad architectural types. Along Utica and 21st Street one is able to observe high density and high traffic.



Aerial Photography

Interpretation of aerial photography of the study area reveals an extensively built out environment with complete civic infrastructure and little open space. Swan Lake and Benedict Park are small parks in the area, but Woodward Park, a large urban park, is just out of the frame to the southwest. The photographs reveal a mature urban forest, especially in the residential areas. Two large megastructures, Hillcrest Medical Center and St. John Medical Center are apparent. The Broken Arrow Expressway is a major linear structure and barrier crossing the photograph east to west. The Union Pacific Railroad clips the northeast corner of the site.

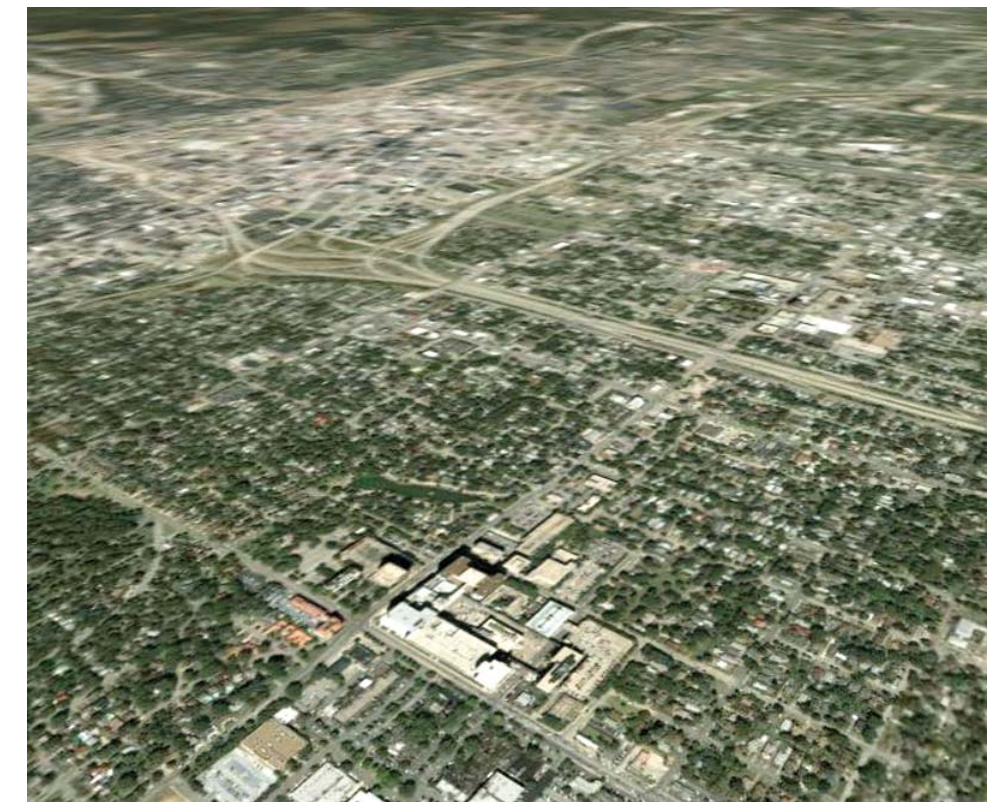

Aerial photography provided by Google Earth: 2005, Google, Inc.

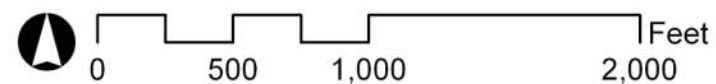

Aerial photography provided by City of Tulsa, Department of Public Works, Engineering Graphics Division.



Midtown Tulsa Redux

Topography

Hypsography and Drainage

The topography of the study area ranges from a high point of 784 feet above sea level at the eastern end of the Broken Arrow Expressway to a low point of 686 feet above sea level located near the southwest corner across the street from Woodward Park. Two parallel ridges run from southwest to northeast and join in a plateau in the northeast quadrant of the area. A shallow valley is created between the ridges where Swan Lake has been dammed. The Broken Arrow Expressway forms a barrier which is a raised embankment on the east end and a trench on the west end.

Drainage of the area is generally good and it is not considered a flood hazard except for localized street flooding during heavy rainfalls. Land north of the expressway generally drains to the northwest and is part of the Elm Creek Watershed. Land south of the expressway generally drains to the south, either to the southwest in the aforementioned valley or to the southeast toward the intersection of Lewis Avenue and 21st Street and is part of the Crow Creek Watershed. The entire area is part of the City of Tulsa stormwater system and is equipped with underground storm sewers.

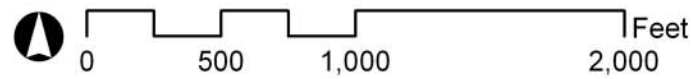
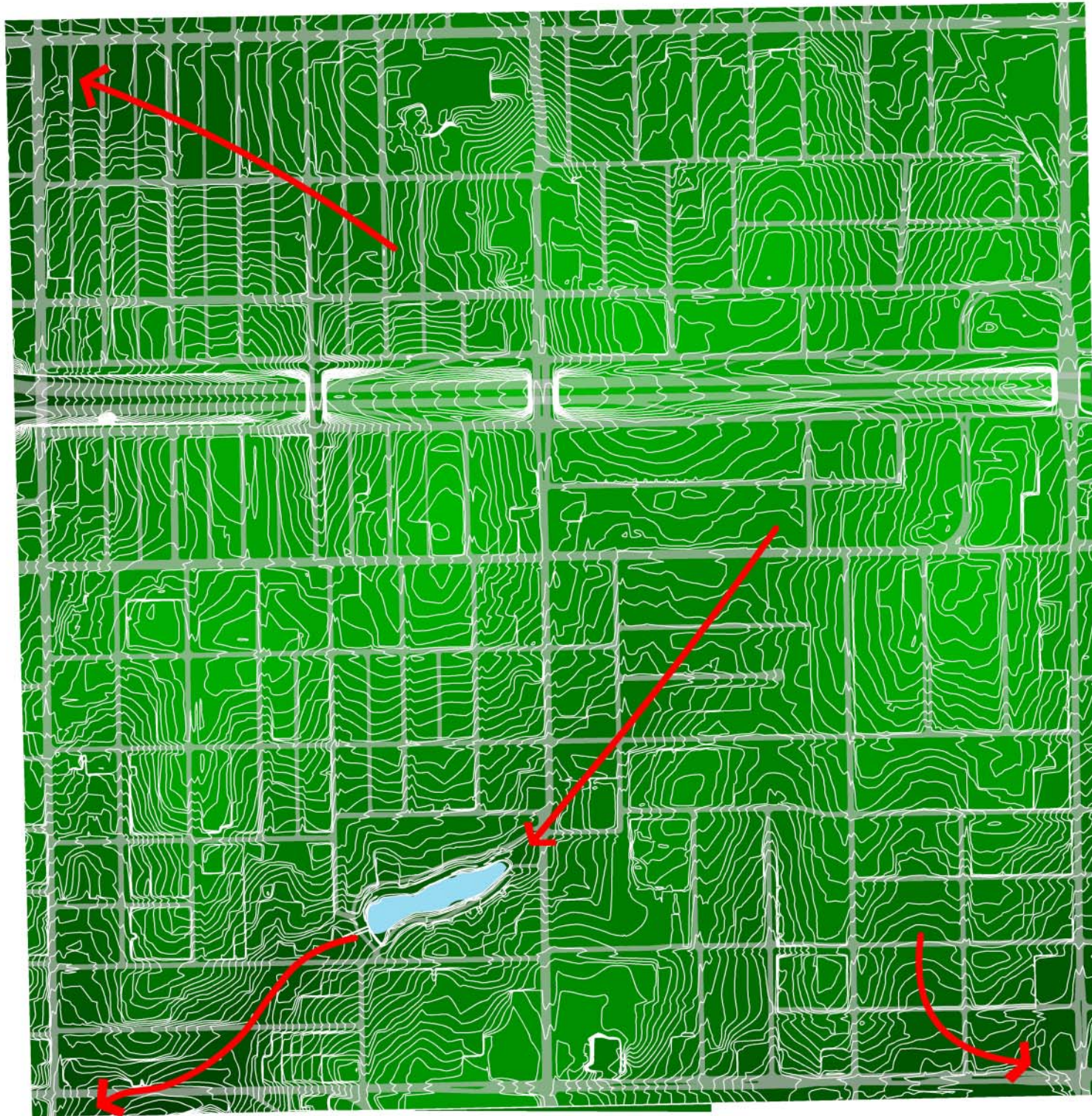

*Survey data from the City of Tulsa, Department of
Public Works, Engineering Graphics Division.*

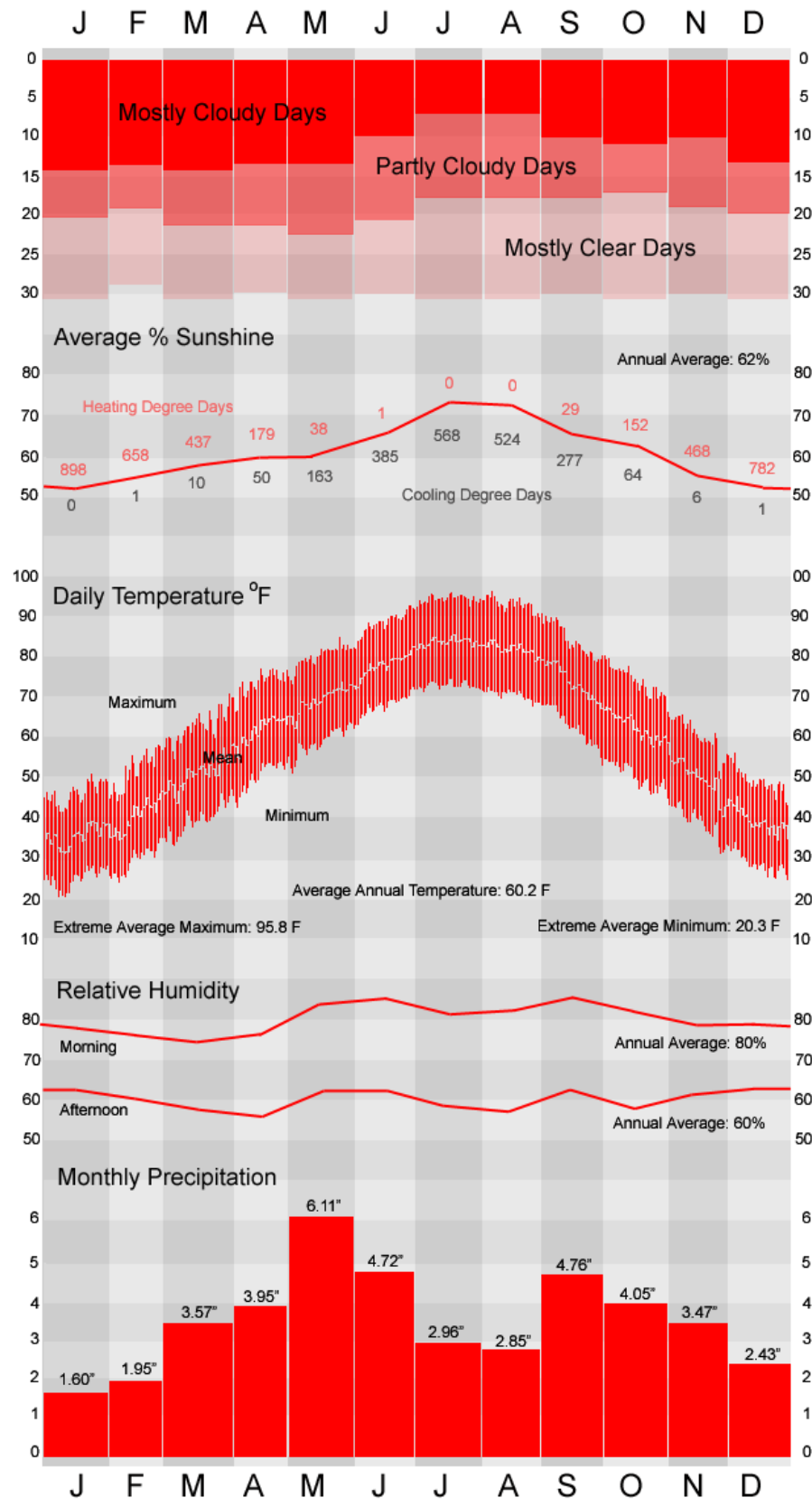

Climatic data obtained from the climatic record book webpage last updated on July 6, 2004 and maintained by the National Weather Service - Tulsa Office at: <http://www.srh.noaa.gov/tulsa/climate/tulrecbook.html>.

Stereographic Sun Path Diagram 36 Degrees North Latitude

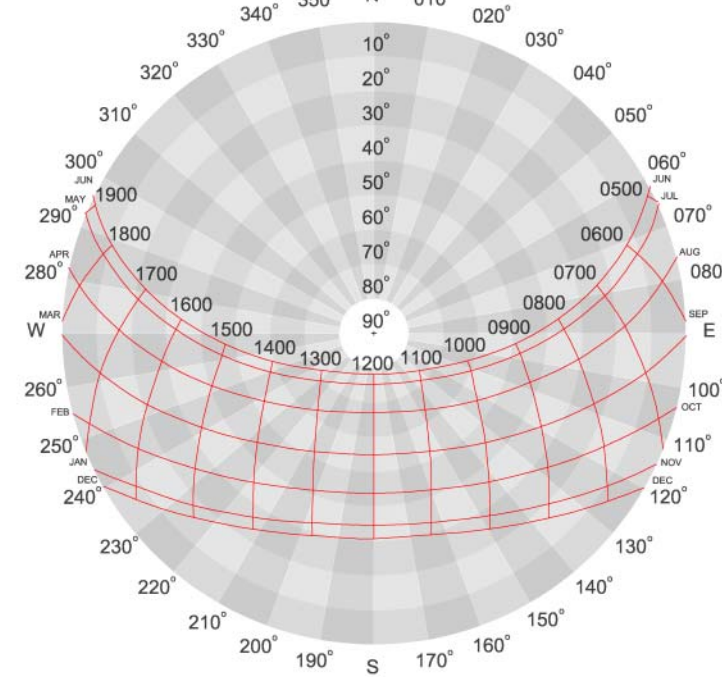

Stereographic sun path diagram adapted from a diagram prepared by Victor Olgay, AIA on page 803, *Architectural Graphic Standards*, Tenth Edition, by Ramsey/Sleeper; John Ray Hoke, Jr. FAIA, Editor, John Wiley and Sons, New York:2000.

Wind Rose

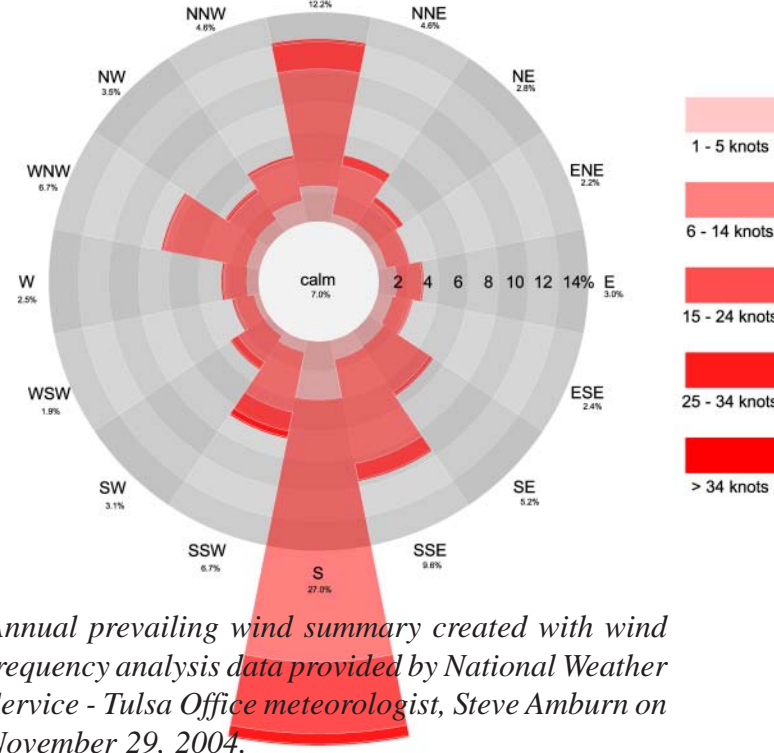

Annual prevailing wind summary created with wind frequency analysis data provided by National Weather Service - Tulsa Office meteorologist, Steve Amburn on November 29, 2004.

Climate Summary

"The city of Tulsa lies along the Arkansas River at an elevation of 700 feet above sea level. The surrounding terrain is gently rolling.

At latitude 36 degrees, Tulsa is far enough north to escape the long periods of heat in summer, yet far enough south to miss the extreme cold of winter. The influence of warm moist air from the Gulf of Mexico is often noted, due to the high humidity, but the climate is essentially continental characterized by rapid changes in temperature. Generally the winter months are mild. Temperatures occasionally fall below zero but only last a very short time. Temperatures of 100 degrees or higher are often experienced from late July to early September, but are usually accompanied by low relative humidity and a good southerly breeze. The fall season is long with a great number of pleasant, sunny days and cool, bracing nights.

Rainfall is ample for most agricultural pursuits and is distributed favorably throughout the year. Spring is the wettest season, having an abundance of rain in the form of showers and thunderstorms.

The steady rains of fall are a contrast to the spring and summer showers and provide a good supply of moisture and more ideal conditions for the growth of winter grains and pastures. The greatest amounts of snow are received in January and early March. The snow is usually light and only remains on the ground for brief periods.

The average date of the last 32 degree temperature occurrence is late March and the average date of the first 32 degree occurrence is early November. The average growing season is 216 days.

The Tulsa area is occasionally subjected to large hail and violent windstorms which occur mostly during the spring and early summer, although occurrences have been noted throughout the year.

Prevailing surface winds are southerly during most of the year. Heavy fogs are infrequent. Sunshine is abundant."

Climatological Overview quoted from the National Weather Service Tulsa Office webpage: <http://www.srh.noaa.gov/tulsa/climate/tulcliover.html>.



Midtown Tulsa Redux

Development History

Sanborn Fire Insurance Maps

The Sanborn Company created detailed fire insurance rate maps for Tulsa and many other cities between 1867 and 1970. The map below is the only map available in 1915. It indicates that at that time only a small portion of the northwest quadrant of the study area had been developed, primarily with single family dwellings. The large composite at the left shows that by 1926 the entire area had rapidly developed with most of the features still found today, including: Swan Lake, Hillcrest Medical Center, St. John Medical Center, Cherry Street Shopping District, Christ the King Church, Lincoln School, Barnard School, and the many housing developments.

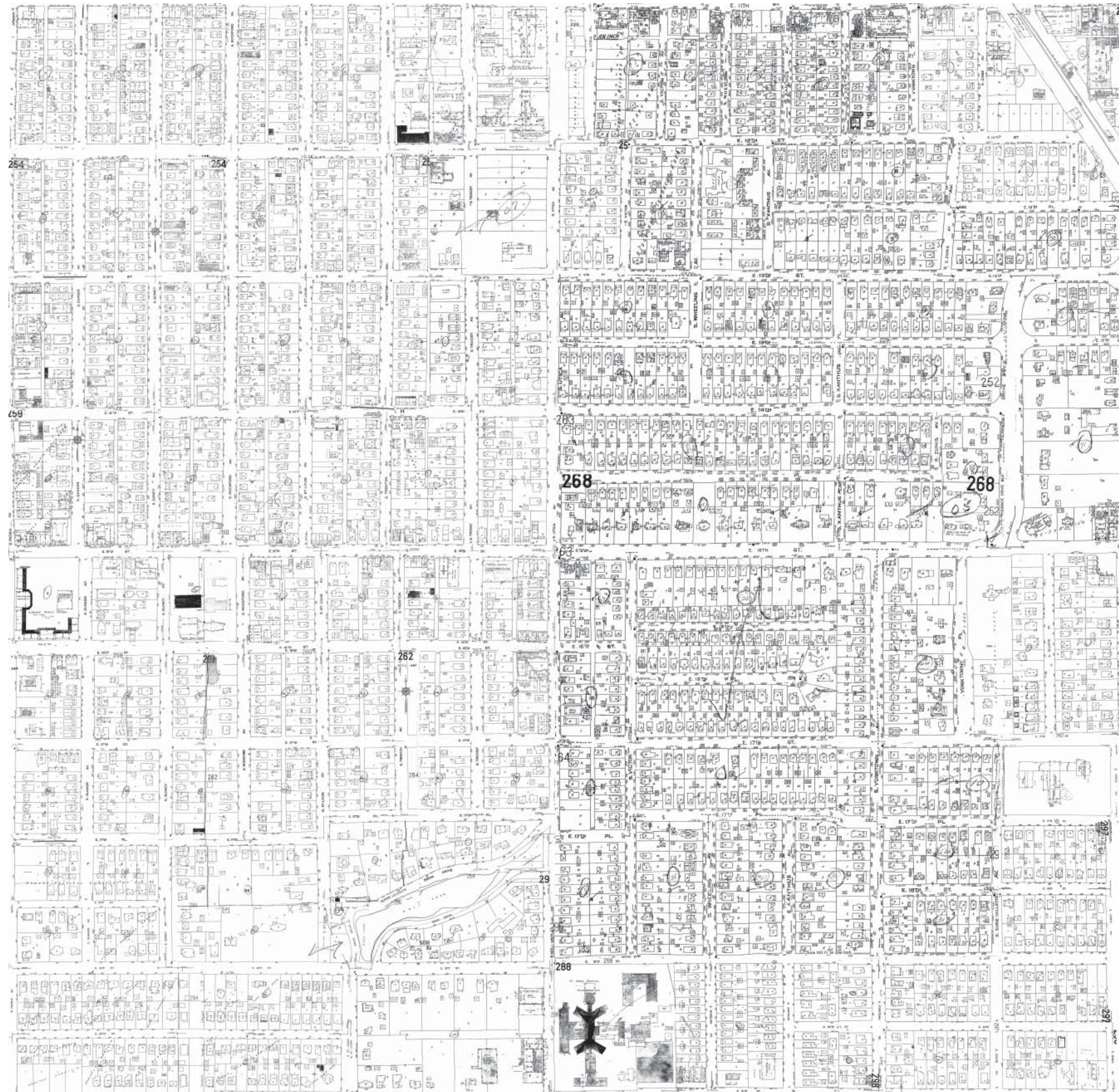

1915

1926

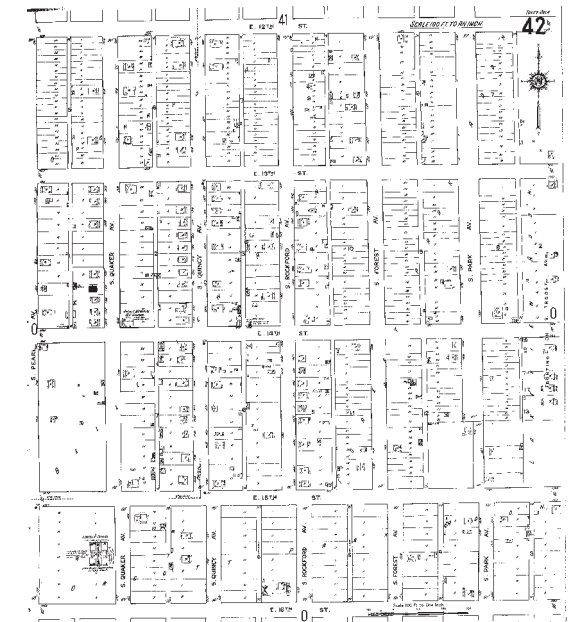

Sanborn Fire Insurance Rate Map, Sheet 42, Tulsa, Oklahoma, created in 1915. Obtained from the Sanborn Map Company, Sanborn Library LLC through Proquest Information and Learning Company at its website: <http://sanborn.umi.com>.



Midtown Tulsa Redux

Sanborn Fire Insurance Rate Map composite created from sheets: 251,252,253,254,255,256,257,258,259,260,261,262,263,264,265,266,267,268,288,293,294,295,296, and 298 of Volume 2, Tulsa, Oklahoma, created between 1915 and 1926, with a revision in 1962. Obtained from the Sanborn Map Company, Sanborn Library LLC through Proquest Information and Learning Company at its website: <http://sanborn.umi.com>.

Land Divisions

Subdivision Additions

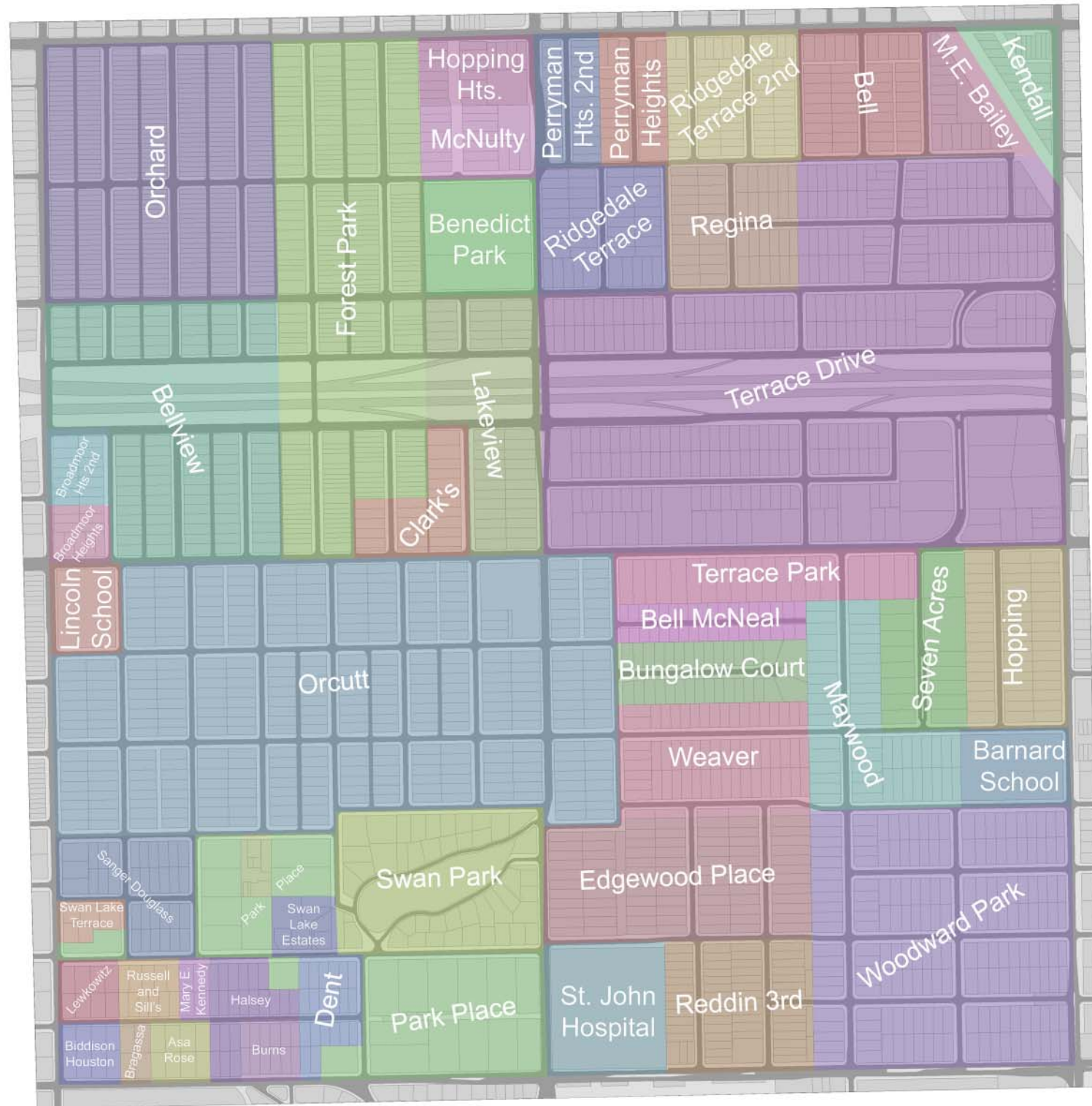

The blocks formed by the subdivision additions generally form a grid of regularly shaped blocks in a slightly irregular structure depending on the sequence of how the additions were platted. The exceptions to the grid include the Swan Lake impoundment, the cul-de-sac addition of Bungalow Court and the dead-end Bell McNeal Addition, which was probably a remnant from previous surrounding additions. The size of additions ranged greatly from 4 lots in the Mary E. Kennedy Addition to 367 lots in the Orcutt Addition, with most of the small additions clustered in the southwest quadrant. Many of the additions are named after large landowners that subdivided their land.

Street right-of-ways range from 50' to 80' with most streets having a 60' right-of-way. Blocks in the Orchard, Bellview, Forest Park, and portions of Orcutt Additions have 15' to 20' alleys. Most streets form part of the grid system and do not appear to be originally planned as a hierarchy. The streets are straight except for a few exceptions. Utica Avenue makes an awkward jog at 17th Place where the right-of-way does not align. Swan Drive forms an organic path around the lake. The Broken Arrow Expressway broke the street and block pattern when it was built with 13th Place and 14th Street now serving as service roads.

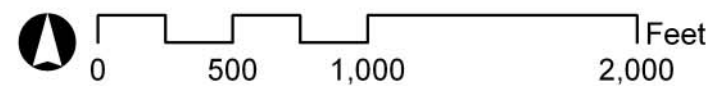

Land Divisions

Lots and Blocks

This area of the City of Tulsa was subdivided and developed chiefly as housing between 1910 and 1930. The northwest quadrant developed first, being the closest to downtown. Most lots were 50' wide by 140' deep with some of the lots in the northwest quadrant having 25' widths, allowing buildings to be built on one, two or more lots. The small residential lots have required land consolidation by many of the area's institutions and later commercial developments. Lots are assembled in blocks ranging from roughly 16 to 24 lots. Interestingly, the blocks west of Utica Avenue generally have the lot frontage on the avenues running north to south and the blocks east of Utica Avenue have the lot frontage on the streets running east to west.

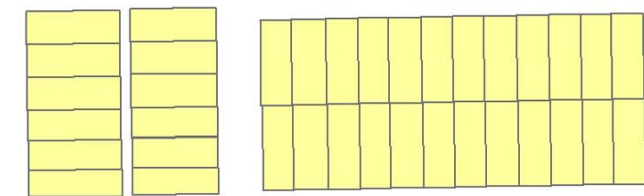
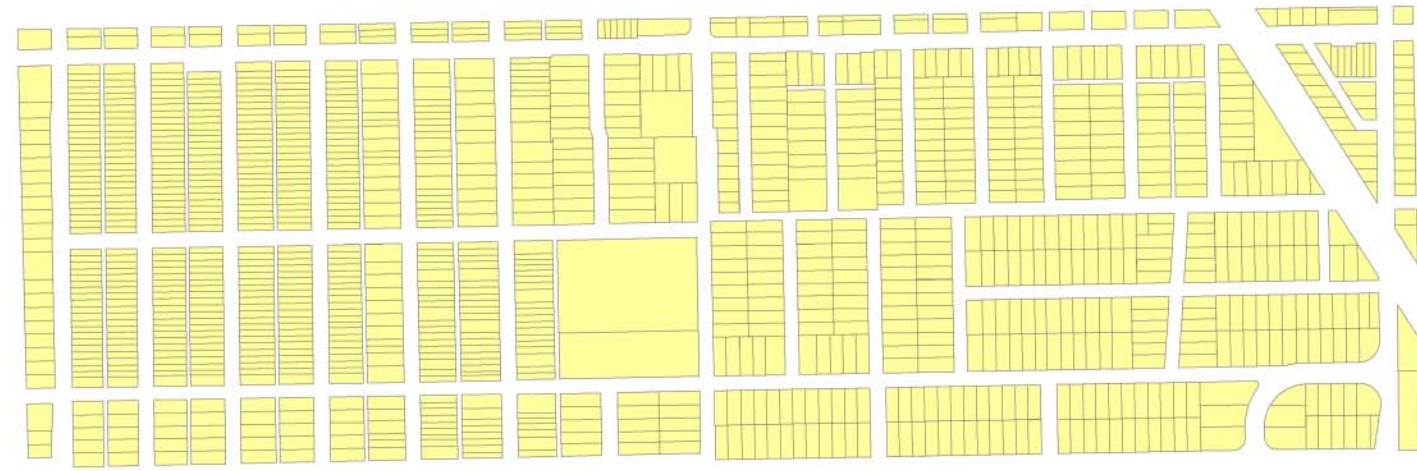

North - South Block

East- West Block

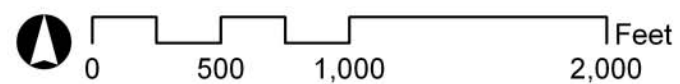

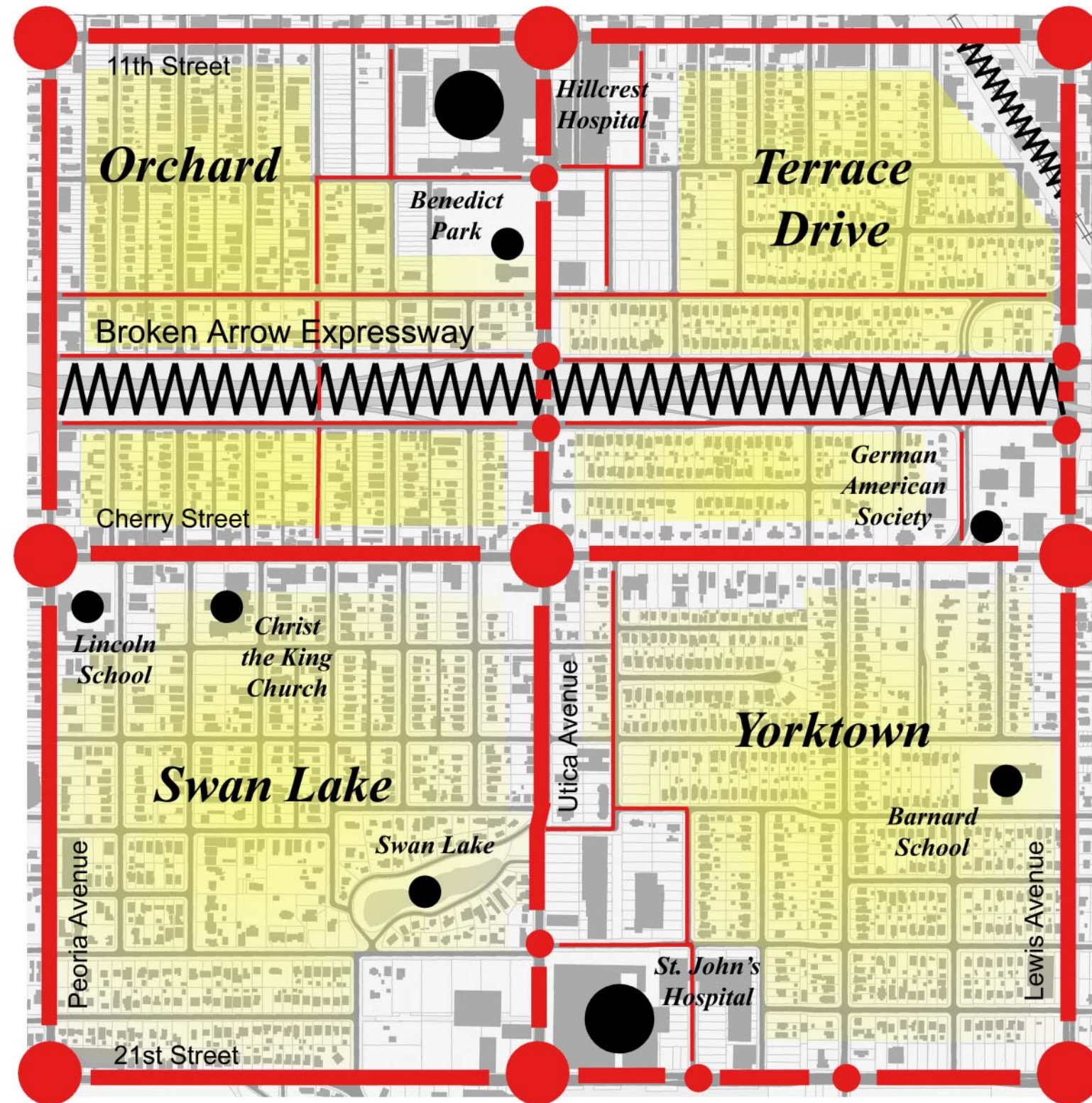

Legibility Analysis

Tulsa Comprehensive Plan District Planning Concept:

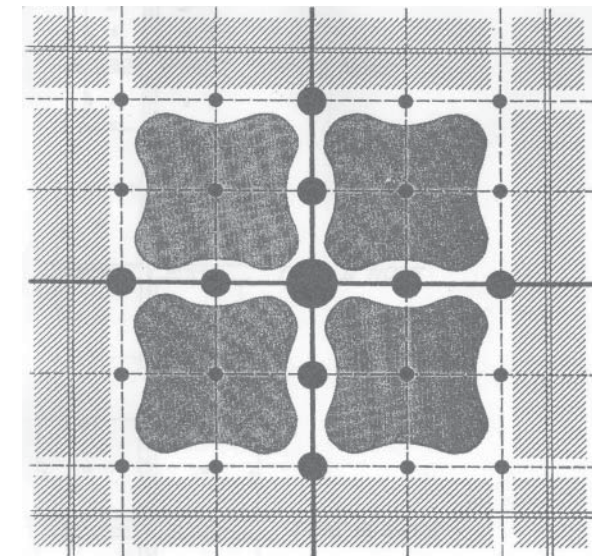

Legend

- Swan Lake** ● Landmarks
- Nodes
- Paths
- Cherry Street
- Edges
- Orcutt** Districts



In *Image of the City*, Kevin Lynch introduces a method to analyze the visual quality or legibility of the city by identifying and mapping landmarks, nodes, paths, edges and districts. Applying this technique to the pilot study area of Midtown Tulsa reveals that the area closely resembles the prototypical district planning concept illustrated in the Comprehensive Plan with a grid of arterial street paths and major intersection nodes. Four residential districts occupy each quadrant, with the northern quadrants split by the edge of the Broken Arrow Expressway. Hillcrest and St. John Medical Centers are major landmarks at each end of Utica Avenue.

Midtown Tulsa Redux

Zoning Map

The majority of zoning for the study area is categorized as residential, primarily RS3 and RM2. Along most of the arterial streets the zoning changes to a commercial or office designation. An attempt has been made to buffer the residential lots from direct contact with commercial development through the use of office lots. Along with the lot zoning it is important to remember that much of this area falls under various special districts found in the Comprehensive Plan, Historic Preservation, and Planned Unit Developments.

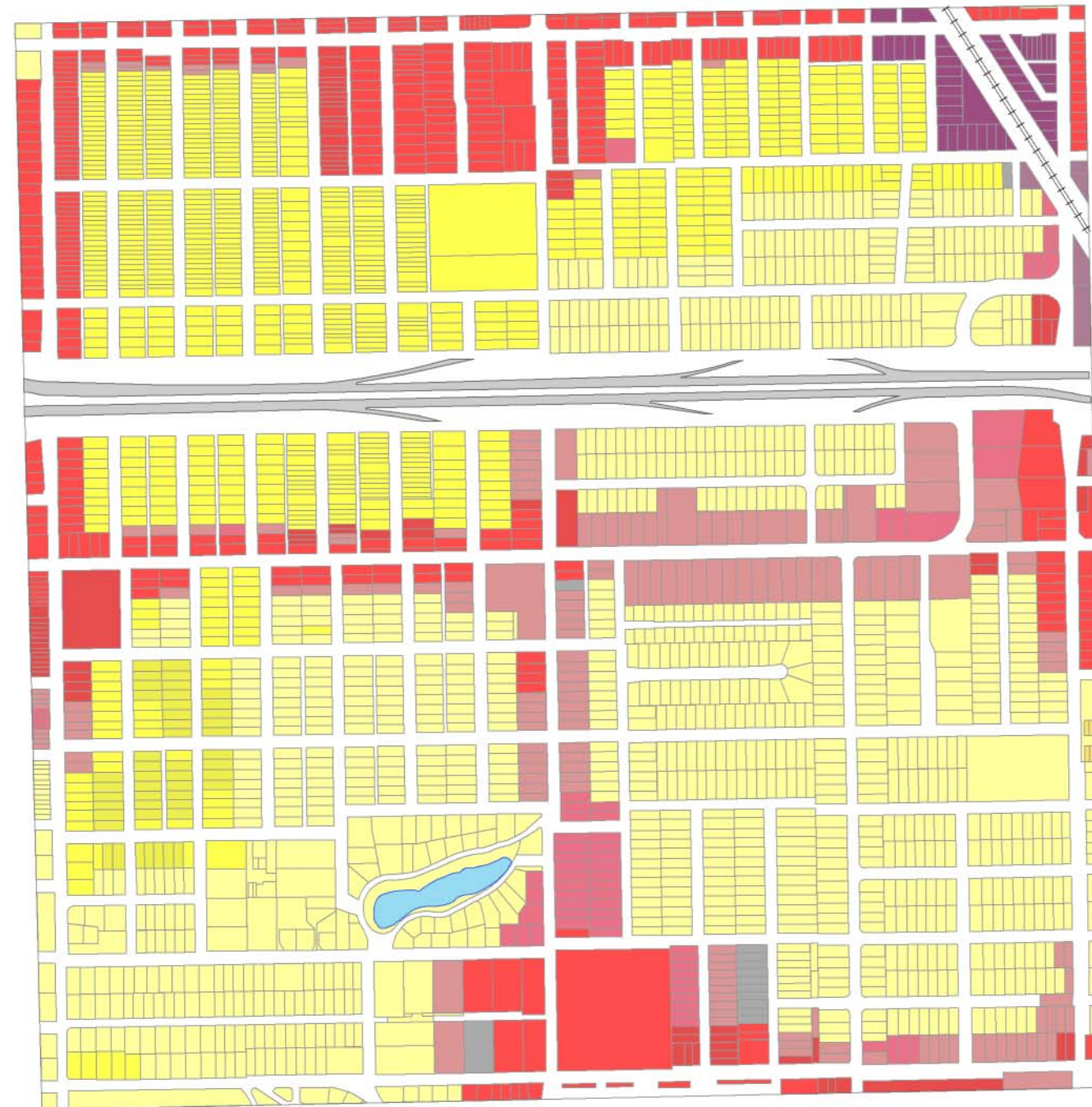

- Commercial High Intensity
- Commercial Shopping
- Industrial Light
- Industrial Moderate
- Office High Intensity
- Office Low Intensity
- Office Medium Intensity
- Office Medium-High Intensity
- Parking
- Residential Duplex
- Residential Multi-Family 2
- Residential Single-Family 3
- Residential Single-Family 4
- Residential Townhouse
- Limits

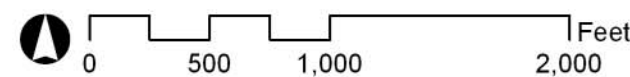

Zoning data was provided by INCOG.



Midtown Tulsa Redux

Land Use

Land use can differ from zoning because of special exceptions, grandfathered lots, and undeveloped sites. This land use map illustrates the lots in the study area, color coded based on the American Planning Association guidelines for common activities. Residential housing has been divided into two sections, single-family and multi-family. Schools, hospitals, religious institutions, and the parking areas associated with their use are categorized as social institutions. Commercial activities include all shopping, business, or trade related activities. A small area of industrial activity still exists near the railroad in the northeastern section of the map. Interestingly, Hillcrest Medical Center is established on both the east and west sides of Utica Avenue, while St. John Medical Center development has focused on the east side due to the necessity to build more urban, vertical additions.



- Mass Assembly
- Commercial Activities
- Industrial Activities
- Leisure Activities
- Natural Resources
- Parking
- Residential Activities
- Residential Multi-Family
- Social Institutions
- Unclassifiable

Land-Based Classification Standards based on American Planning Association guidelines

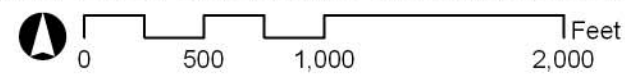

Comprehensive Plan Special Districts

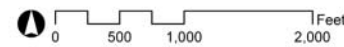
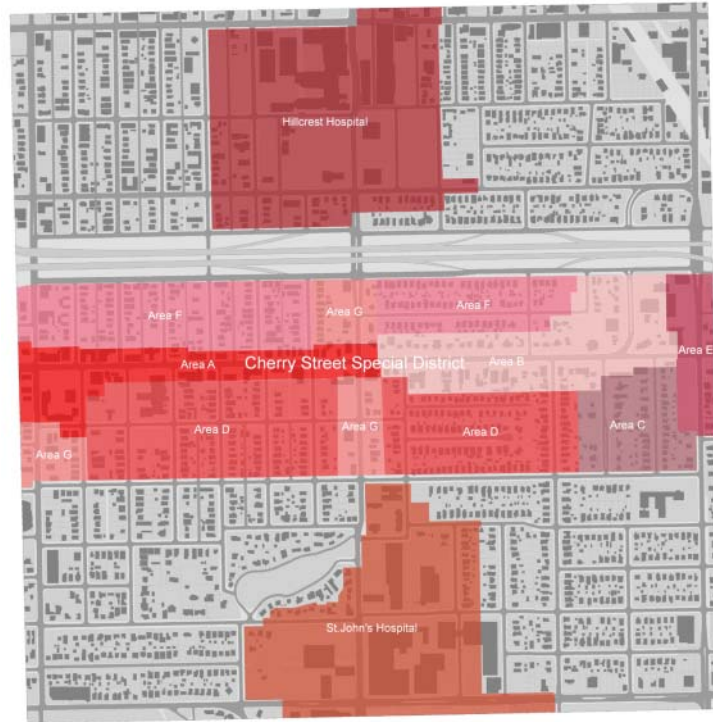

Planned Unit Development Overlay Zoning

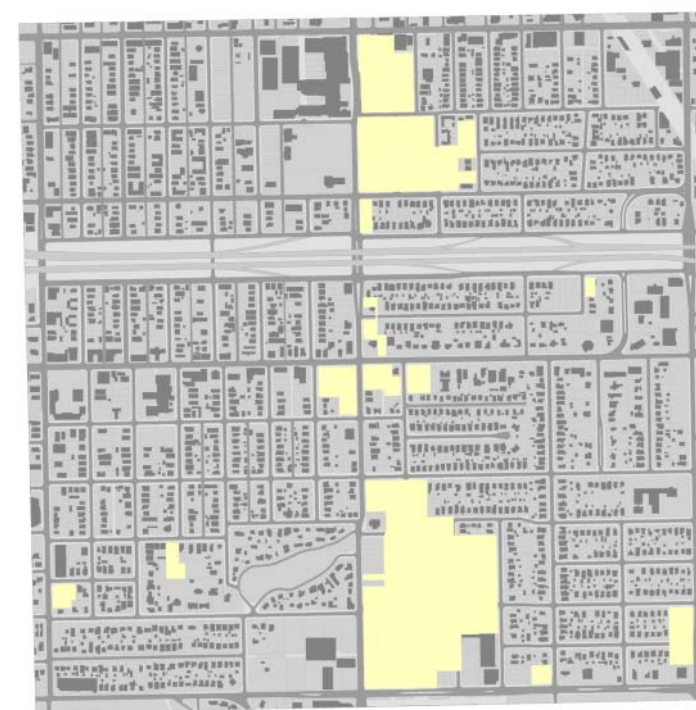

Special Districts

Planning and Zoning

The City of Tulsa Comprehensive Plan and Zoning Ordinance define and incorporate a variety of special districts. The study area is included in two adjacent planning districts. The area north of the Broken Arrow Expressway is in Planning District 4 and the area south of the Broken Arrow Expressway is in Planning District 6.

Special Planning Districts

The study area includes parts of three special planning districts: the Hillcrest Medical Center Special District, the St. John and Utica Square Special District and the Cherry Street Planning District. The Cherry Street District is further divided into seven sub-districts. Sub-district A includes the medium intensity commercial shopping area along 15th Street west of Utica Avenue. Sub-district B includes the light intensity office district east of Utica Avenue. Sub-districts E and G include commercial property and activity nodes. Sub-districts C, D and F are buffer areas of lesser intensity separating lower and higher intensity uses.

Historic Preservation Overlay Zoning



Combined Special Districts

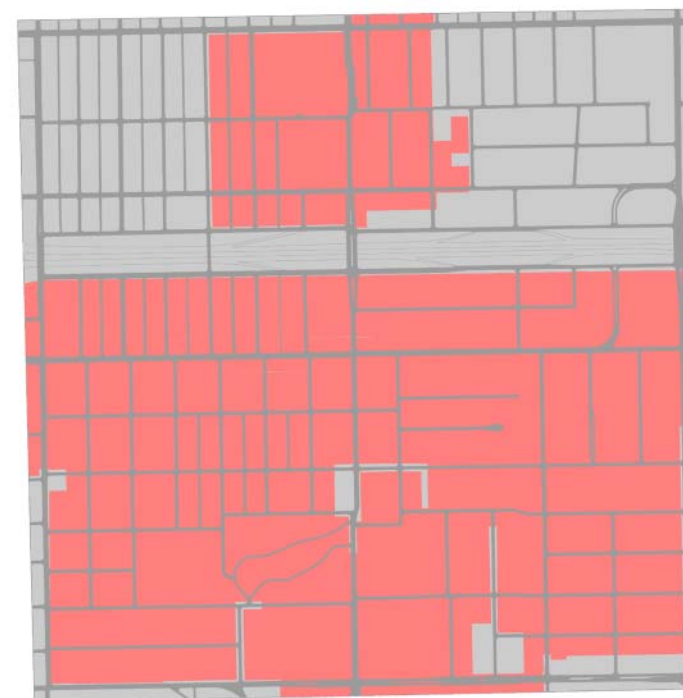

Planned Unit Development Overlay Zoning

All of the special planning districts recommend Planned Unit Developments for redevelopment. Large PUDs exist at Hillcrest and St. John Medical Centers. Several more are clustered around the 15th Street and Utica Avenue intersection.

Historic Preservation Overlay Zoning

Three neighborhoods have requested and have been zoned Historic Preservation Districts: Swan Lake, Yorktown and Gillette. All three have design guidelines which are administered by the Tulsa Preservation Commission.

For all intents and purposes the entire area south of the Broken Arrow Expressway and nearly all of the study area is in some type of special district.



Midtown Tulsa Redux

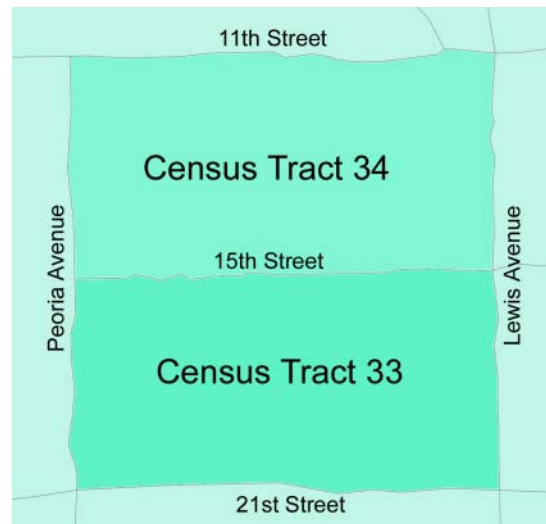

City of Tulsa

	1990 Census	2000 Census	Difference	% Change
Population	367,302	393,051	25,749	7%
Population Density per Sq. Mile	2,135	1,985	-150	-7%
Housing Units	176,211	179,405	3,194	2%
Housing Units per Sq. Mile	890	815	-75	-8%
Occupied Units	155,447	165,743	10,296	7%
Occupancy Rate	88%	92%	4%	5%
Rental Units	68,687	73,509	4,822	7%
Owner Occupied Units	86,760	92,234	5,474	6%
Ownership Rate	56%	56%	0%	0%
Median Household Income	25,708	35,316	9,608	37%
Median Gross Rent	358	511	153	43%
Median Value	60,000	81,900	21,900	37%

Census Tract 33

	1990 Census	2000 Census	Difference	% Change
Population	2,447	2,223	-224	-9%
Population Density per Sq. Mile	4,894	4,446	-448	-9%
Housing Units	1,391	1,272	-119	-9%
Housing Units per Sq. Mile	2,782	2,544	-238	-9%
Occupied Units	1,196	1,155	-41	-3%
Occupancy Rate	86%	91%	5%	6%
Rental Units	612	619	7	1%
Owner Occupied Units	584	536	-48	-8%
Ownership Rate	49%	46%	-2%	-5%
Median Household Income	24,882	36,059	11,177	45%
Median Gross Rent	347	538	191	55%
Median Value	71,700	106,100	34,400	48%

Census Tract 34

	1990 Census	2000 Census	Difference	% Change
Population	2,274	2,413	139	6%
Population Density per Sq. Mile	4,548	4,826	278	6%
Housing Units	1,624	1,482	-142	-9%
Housing Units per Sq. Mile	3,248	2,964	-284	-9%
Occupied Units	1,195	1,330	135	11%
Occupancy Rate	74%	90%	16%	22%
Rental Units	871	1,020	149	17%
Owner Occupied Units	324	310	-14	-4%
Ownership Rate	27%	23%	-4%	-14%
Median Household Income	16,219	24,456	8,237	51%
Median Gross Rent	286	424	138	48%
Median Value	43,500	61,900	18,400	42%

Demographics

Census Tract Data

The Midtown Tulsa pilot study area primarily consists of two census tracts, numbers 33 and 34. Tract 33 is located south of 15th Street and tract 34 is located north of 15th Street. City of Tulsa summary data is provided for comparison purposes.

Census Tract 33 Analysis

The data suggests that while the population of the tract has decreased over the ten year sample period, the tract still has almost 2.5 times the population density and number of housing units than the city average. The tract has seen significant increases of household income, median gross rent and median property value, outperforming the city's increases in the same timeframe. The number of housing units has decreased by almost ten percent, with all of the loss in owner occupied units, while rental units remaining steady. Even with the loss of housing units and the decrease of population, occupancy rates have increased to near the citywide average.

Census Tract 34 Analysis

Like tract 33, census tract 34 is a dense urban area that has seen significant improvements in median household income, median gross rent and median property value, although this tract was and remains significantly poorer. Tract 34 also lost almost ten percent of its housing units, possibly to hospital expansion, but its population increased by six percent. To accommodate the growth, the occupancy rate soared from 74% to 90% with a significant increase in rental units. This district has half the home ownership rate of its southern neighbor.



Midtown Tulsa Redux

All data from the United States Census: 1990 - Summary Tape SF3 and 2000 Summary File SF3, sampled data at census tract level.

Population Density

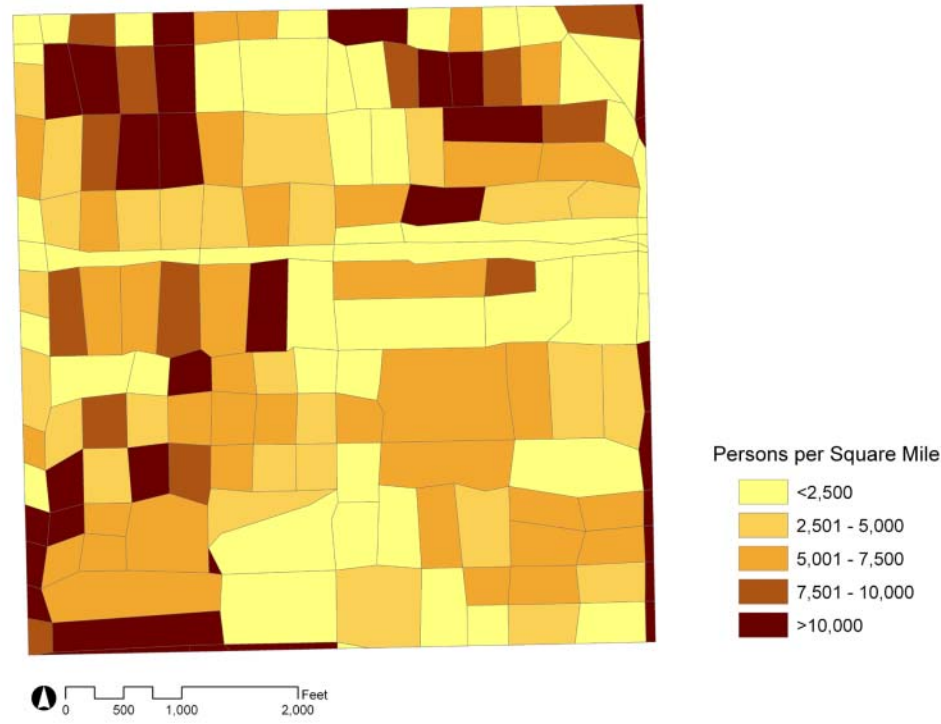

Minority Population

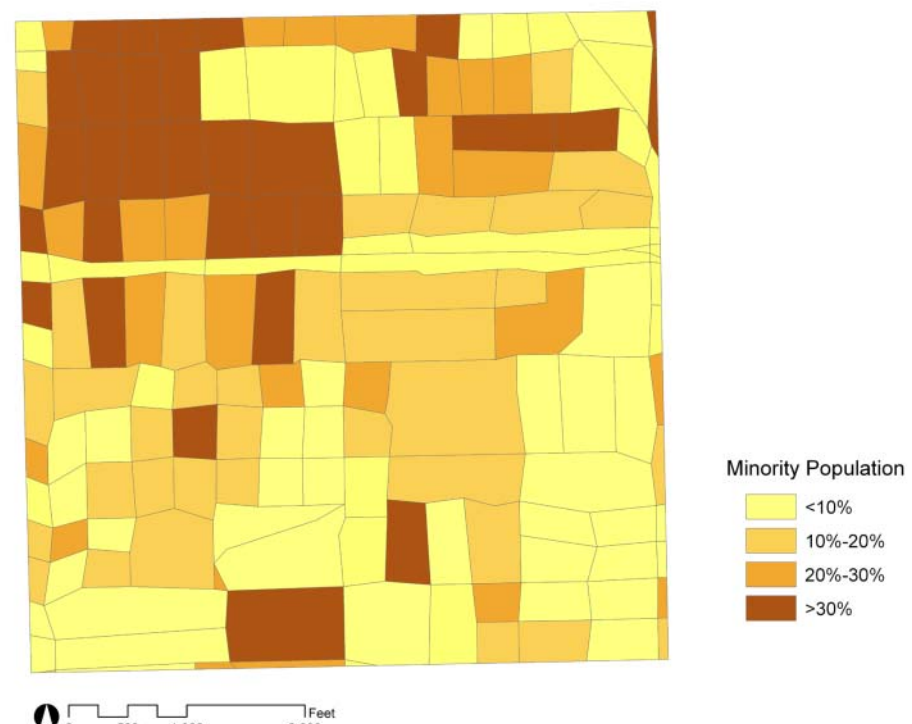

Age

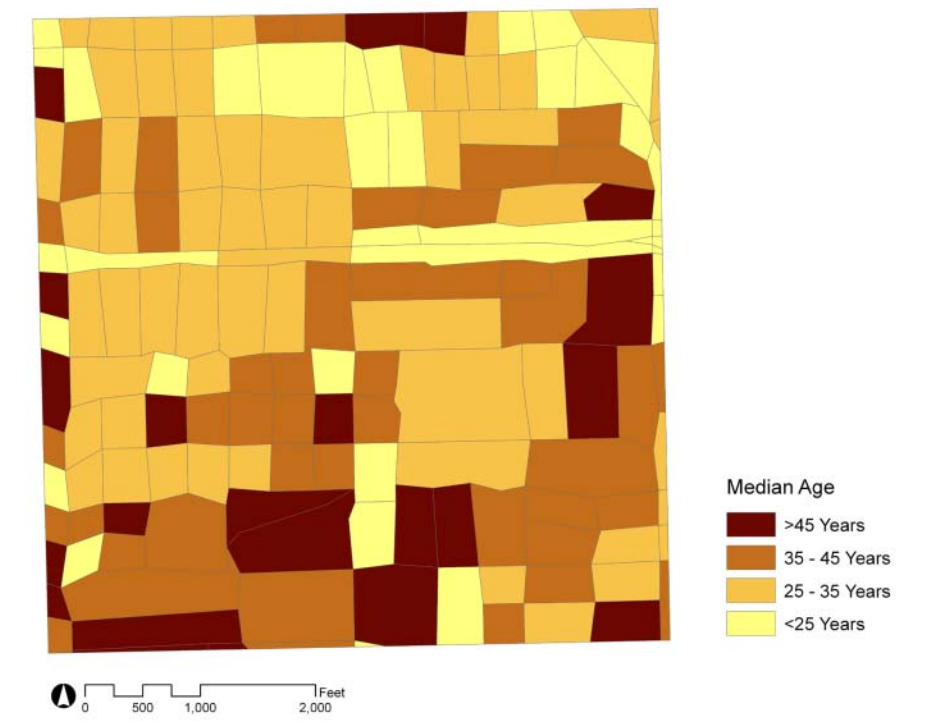

Rental Housing

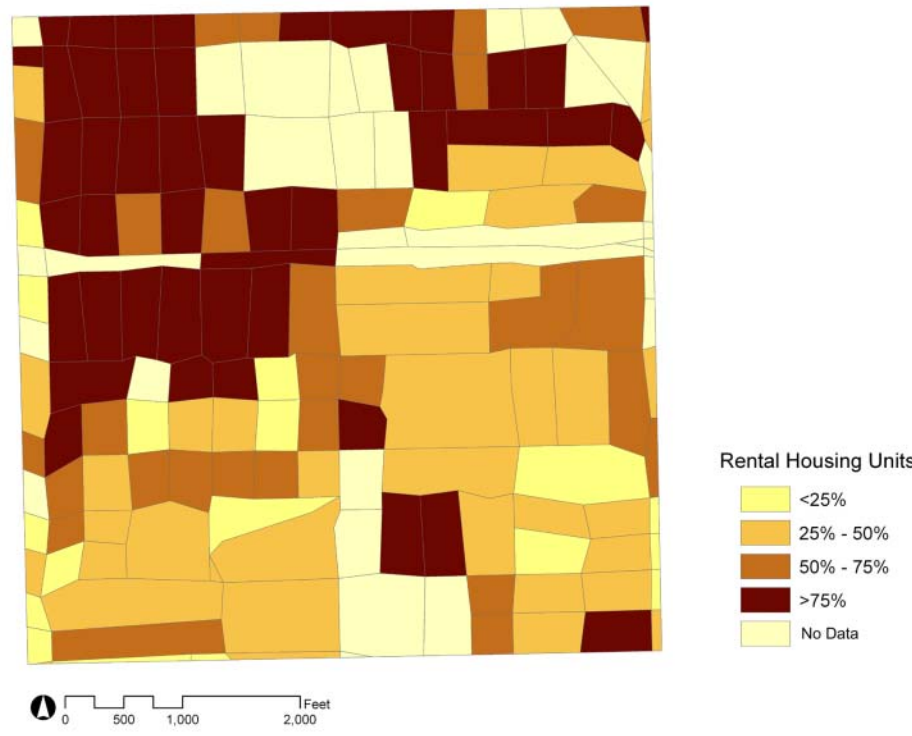

Demographics

Census Block Data

Population Density

The Midtown Tulsa pilot study area has an overall population density of 4,636 persons per square mile, which is much higher than the city of Tulsa average of 1,985 persons per square mile. The northwest quadrant appears to have the highest density, while the southeast quadrant the lowest. High density pockets are apparent where concentrations of multi-family housing are located, which occurs in all quadrants except the southeast.

Minority Population

Eighty percent of residents in the study area are white compared to an average of seventy-three percent citywide. Of the 960 minority residents, 296 are African-American, 255 are Native-American, 244 are Hispanic and 51 are Asian, with the rest classified as other. The northwest quadrant has the largest minority population with more than 30% in many blocks. The southeast quadrant has the smallest minority population with less than 10% in many blocks.

Age

The median age north of 15th Street is 31.3 years, while the median age south of 15th Street is 37.3 years, compared to the Tulsa median age of 34.1 years. Blocks in the historic districts of Swan Lake and Gillette are the oldest with median ages higher than 45 years.

Rental Housing

The area north of 15th Street and west of Utica Avenue has a heavy concentration of rental housing. In fact, more than 75% of all occupied housing units are lease units. Areas near Swan Lake and in the southeast quadrant are predominantly owner occupied.

All data from the United States Census: 2000 - Summary File SF1 census block data.



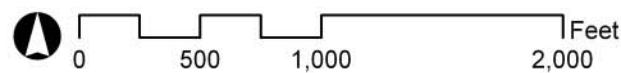
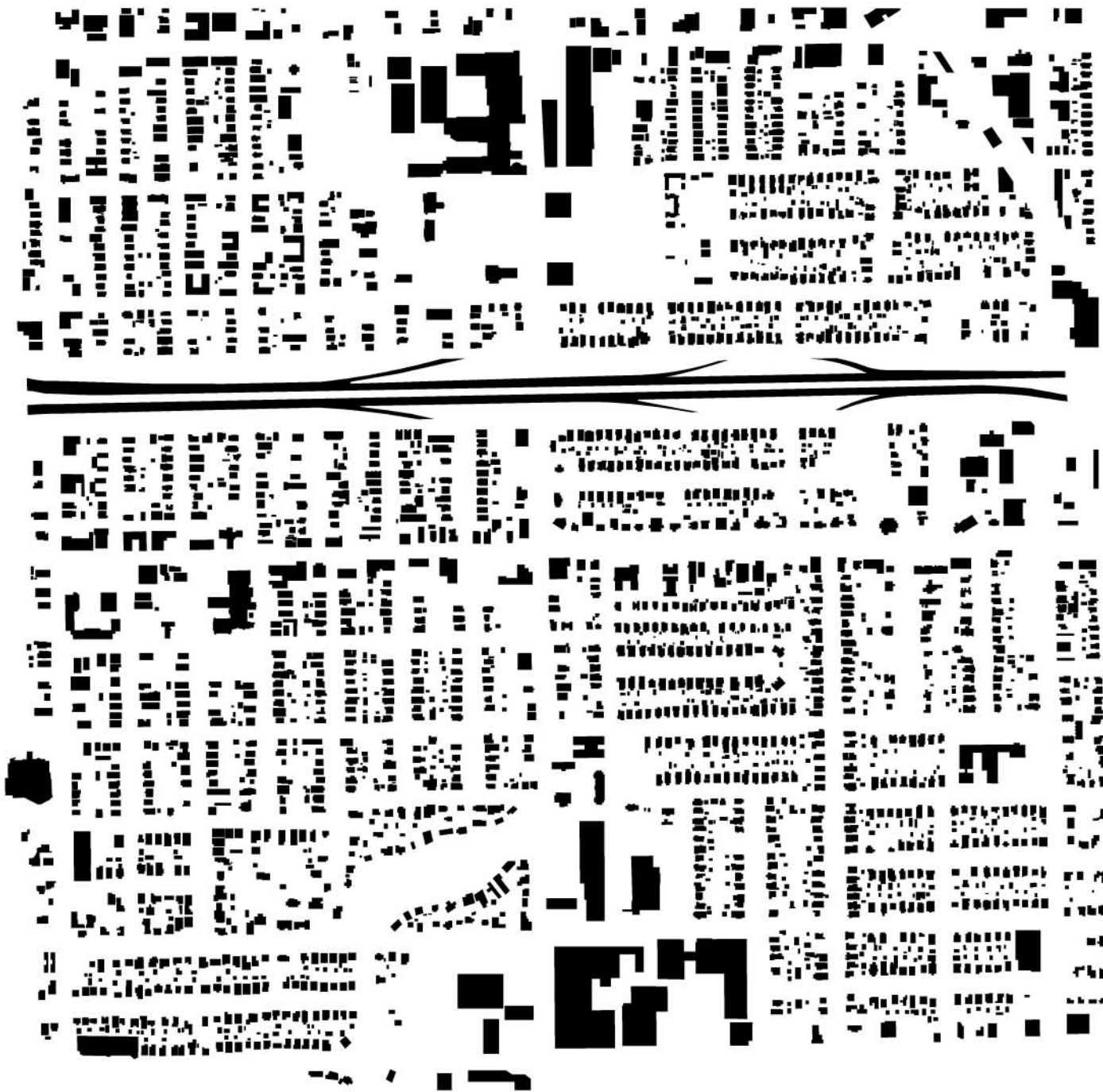

Mass/Void

This map shows buildings and other structures as positive and everything else as negative void in order to measure the grain and texture of the urban fabric. Grain is the degree of fineness or coarseness in an urban area. Texture is the degree of mixture of fine and coarse elements.

The majority of the subject area is of fine grain and uniform texture. The notable exceptions are 1) the two hospital complexes at either end of Utica Avenue, which are examples of coarse grain, and 2) the buildings along the major arterial streets bordering and running through the subject area, which are of slightly more uneven texture than the abutting neighborhoods.

Total estimated number of buildings in the study area 2,890

Total estimated number of buildings with a footprint larger than 4,000 square feet in the study area 137

An estimate of impervious area reveals that roughly sixty (60)percent of the study area is paved or covered by buildings.



Impervious Area

Buildings	19%
Streets	18%
Parking	11%
Driveways	9%
Walks/Other	3%

Vehicular Circulation

The map shows the hierarchy of roads, the mostly heavily used being the arterial streets, the collector streets which collect traffic from the neighborhood, the residential streets with housing facing them, the parkways as for instance the one around Swan Lake and then alleys which serve as the service roads in the neighborhoods. The Broken Arrow Expressway reduces access to the northern quadrants. The blocks west of Utica Avenue are more interconnected when compared to the east.



- Arterial
- Collector
- Parkway
- Residential
- Alleys
- 24 Hour Traffic Counts
- Number of Intersections per Quadrant

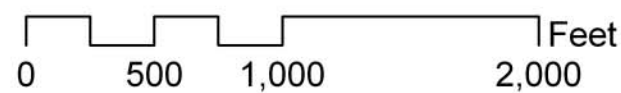



Traffic count data cited from the INCOG website:
<http://www.incog.org/transportation/trafficdata/Traffic%20Counts%20Map.htm>

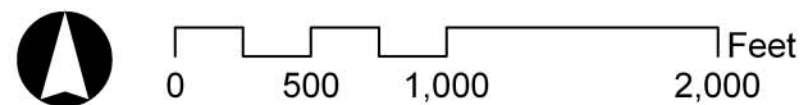
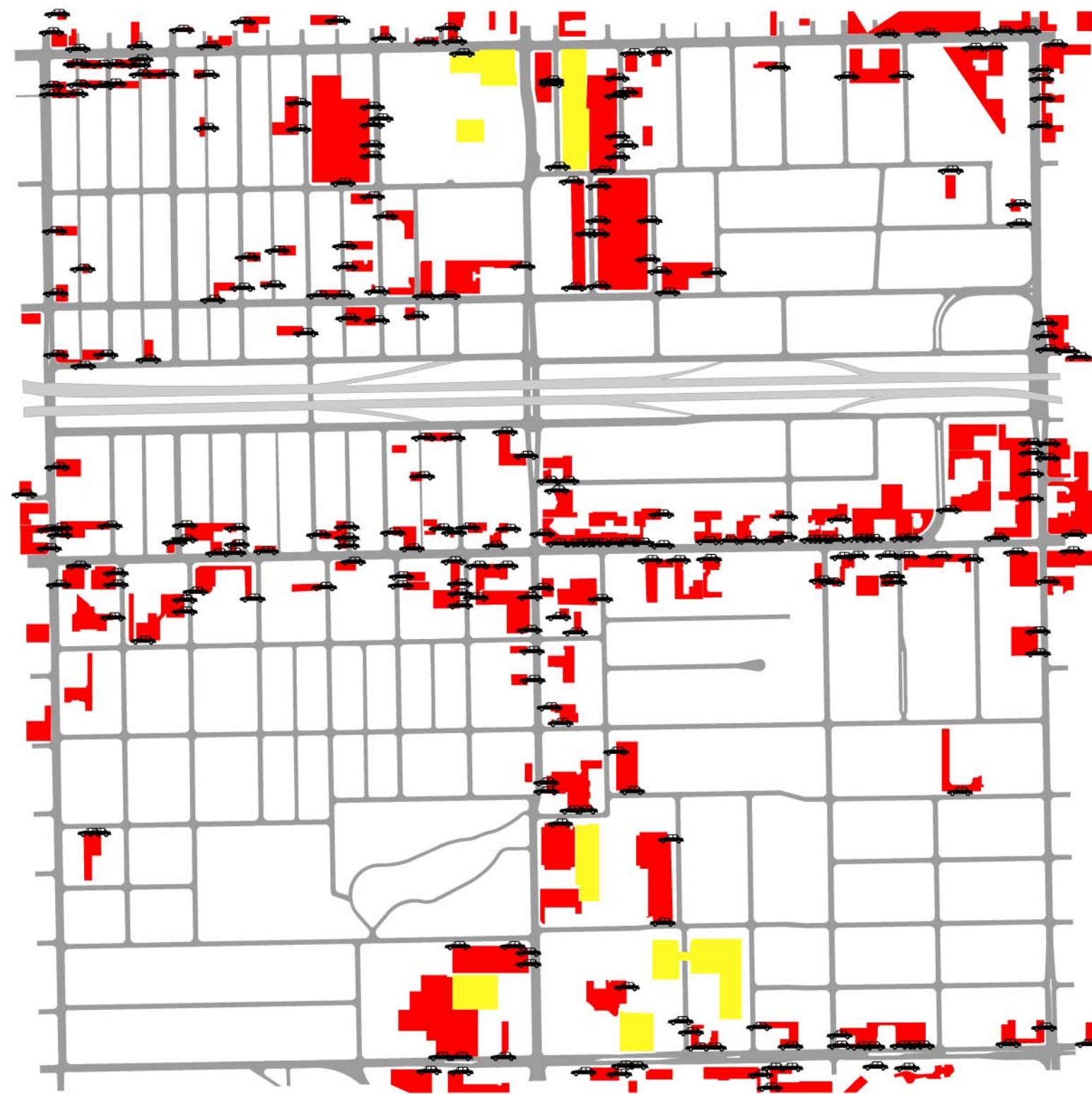



Parking

1. Total footprint of parking	80.8 acres
a) Surface parking area	72.0 acres
b) Structured parking area	8.8 acres
2. Estimate of number of parking lots	
a) Surface parking	179
b) Structured parking	7
3. Estimate of parking spaces	14,437 spaces
a) Surface lots	8,961 spaces
b) Structured parking	5,476 spaces
4. Total number of access points to parking lots	186
a) Number of access points to Cherry Street parking lots	86
b) Number of access points to Utica Avenue parking lots	54
5) Estimated number of structures removed for expressway	200
a) Estimated number of structures removed for all parking	200
b) Estimated number of structures removed for hospital parking	160

-  Curbcuts
-  Surface Parking Lots
-  Parking Structures



Parking Proximity

Parking proximity is analyzed by applying a buffer of 300 feet radius from the larger buildings in the area of study. It is interesting to note that the buffer does not exceed the existing parking lots.

1. Footprint of buildings with footprint greater than 4,000 sq. ft 2,122,545 sq. ft.
2. Footprint of buildings with footprint less than 4,000 sq. ft. 4,051,926 sq. ft.
3. Footprint of surface parking area 3,138,161 sq. ft. (8,966 spaces)
4. Footprint of structured parking area 1,918,780 sq. ft. (5,482 spaces)
5. Buildings to parking ratio
 - a) Total building footprint area to parking footprint area 1:87
 - b) Buildings with footprint greater than 4,000 sq. ft. to parking footprint area 1:1.66
6. Building footprint area to parking spaces
 - a) All buildings 280 sq. ft. per space
 - b) Larger buildings 147 sq. ft. per space

Considering parking areas are more a part of the commercial buildings, every 147 sq. ft of commercial building footprint has one parking space. If an average commercial building is two stories, then approximately 300 square feet of building floor area is accommodated per parking space.

Note: 1 parking space = 350 sq. ft. in these calculations



- Buildings with footprints greater than 4,000 sq. ft.
- Buildings with footprints less than 4,000 sq. ft.
- 300 foot radius buffer from larger buildings
- Surface parking lots
- Structured parking decks



Midtown Tulsa Redux

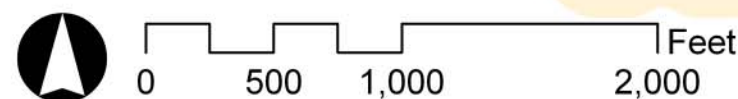

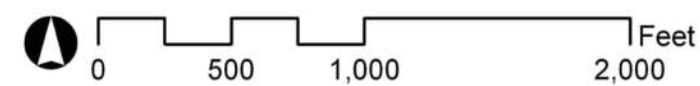
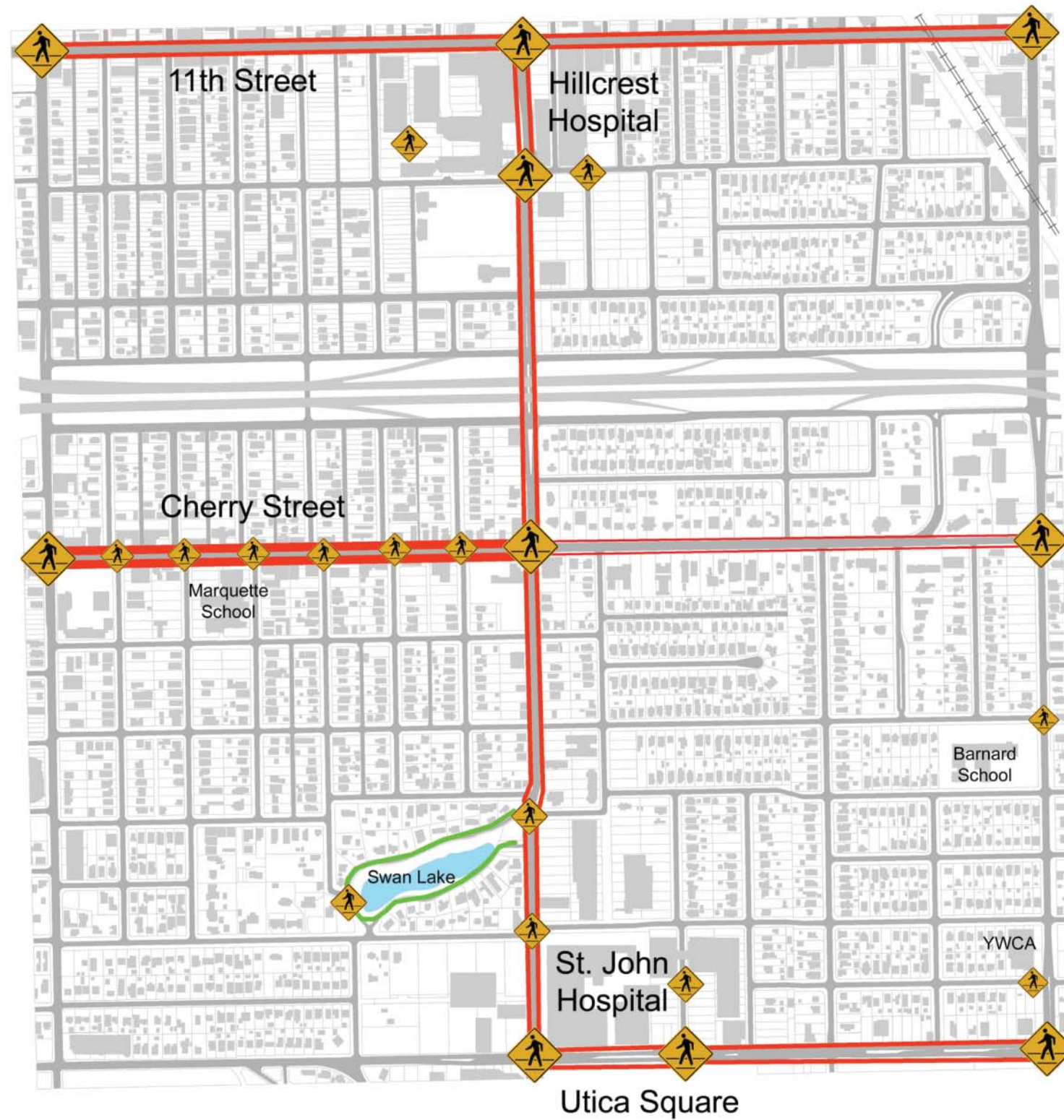

 Pedestrian Node

Pedestrian Circulation

The study area contains several pedestrian nodes which attract foot traffic. The Cherry Street shopping district has numerous shops, restaurants, and night spots. The farmer’s market at Lincoln School on Saturday morning is a recurring pedestrian event during the summer. Both Hillcrest and St. John Medical Centers generate significant local traffic, including many people with disabilities. St. John also sees significant traffic from Utica Square across 21st Street. Swan Lake is frequently used for strolls. Marquette and Barnard Schools have several student street crossings, the most significant at Barnard School and Lewis Avenue.



A pedestrian crossing sign on Cherry Street at the intersection of 15th Street and Peoria Avenue.



Midtown Tulsa Redux

New Development, Process for Approval, City of Tulsa

Project X

Contract Phase	Letter of Intent, Legal Description, Abstract, Title Work, ALTA Survey, Zoning and Building Permit, Research, Phase I & II Environmental Survey, Pricing
Due Diligence Phase	Preliminary Zoning Discussions, Zoning Confirmation, Existing Zoning/PUD Overlay, Title Search, Abutting Property Record Plat, FEMA Floodplains, Topo Map, Utilities
Planning Phase	Site Analysis, Conceptual Layout, Conceptual Site Plan
Platting Phase	Zoning Code & Criterias, Topo Survey, Geotech Report, Pre-development Meeting, Plat, Technical Advisory Committee Meeting, Deed of Restrictive Covenants, Utilities, Construction Documents, Final Plat
Construction Phase	Soil Erosion/Sedimentation, Grading, Water, Sanitary Sewer, Storm Sewer, Conduits, Paving, Franchise Utilities, Final Inspections, As-Constructed Drawings
Building Permit Phase	Final Plat released from Public Works, Planning Commission recommends Approval, City Council Approval, Filing Final Plat, Detailed Site Plan, Landscape Plan, Building Construction Starts, Occupancy Permit
Property Closing Phase	ALTA/ACSM Survey, Current Title Option, Title Commitment Policy, Unresolved Title Issues

Summarized from Planning and Development of New Additions and Developments, Real Property Law Section Joint Fall Seminar by Jerry W. Ledford, P.E., P.L.S., September 21, 2001.



Process

New Development Process

Planning and Zoning site plan review and approval is required in the City of Tulsa for any multi-family, commercial or industrial development prior to the issuance of any building permits. In the initial stages of a new project or development, it is important to have a clear understanding of the City’s review process. After a developer has initiated the contract phase, he or she moves into due diligence. This is followed by the planning phase, platting phase, construction phase, building phase and finally there is the property closing phase.

If a new development is not allowed due to existing zoning restrictions, the applicant/developer has several ways to proceed. They can apply for a rezoning or planned unit development (PUD) from the Planning Commission or apply for a special exception or variance from the Board of Adjustment. All of these choices would lead to public hearings.

In Tulsa, the option to have a Planned Unit Development (PUD), which is an alternative to conventional development where the specific piece of land is under common ownership and a development plan for this specific piece of land is submitted for public review. The main purpose of a PUD, according to the Tulsa Zoning Ordinance, Title 42, Chapter 11, is to help encourage “innovative land development while maintaining appropriate limitation on the character and intensity of use and assuring compatibility with adjoining and proximate properties and also to permit greater flexibility within the development to best utilize the unique physical features of the particular site”.

This supplemental zoning must be approved by the Planning Commission and City Council. In the initial stages of the PUD process, a developer obtains approval of the preliminary and final plat. Also depending on the complexity of the zoning and the project’s motive, it may undergo several approvals phases during review. The Site Plan review requires a detailed drawing which indicates the building footprint location and site, proposed parking spaces, proposed signage, landscape plan, and a drainage plan. A complete list of requirements for approval may be found in the Zoning Ordinance.



Midtown Tulsa Redux

Group Interviews

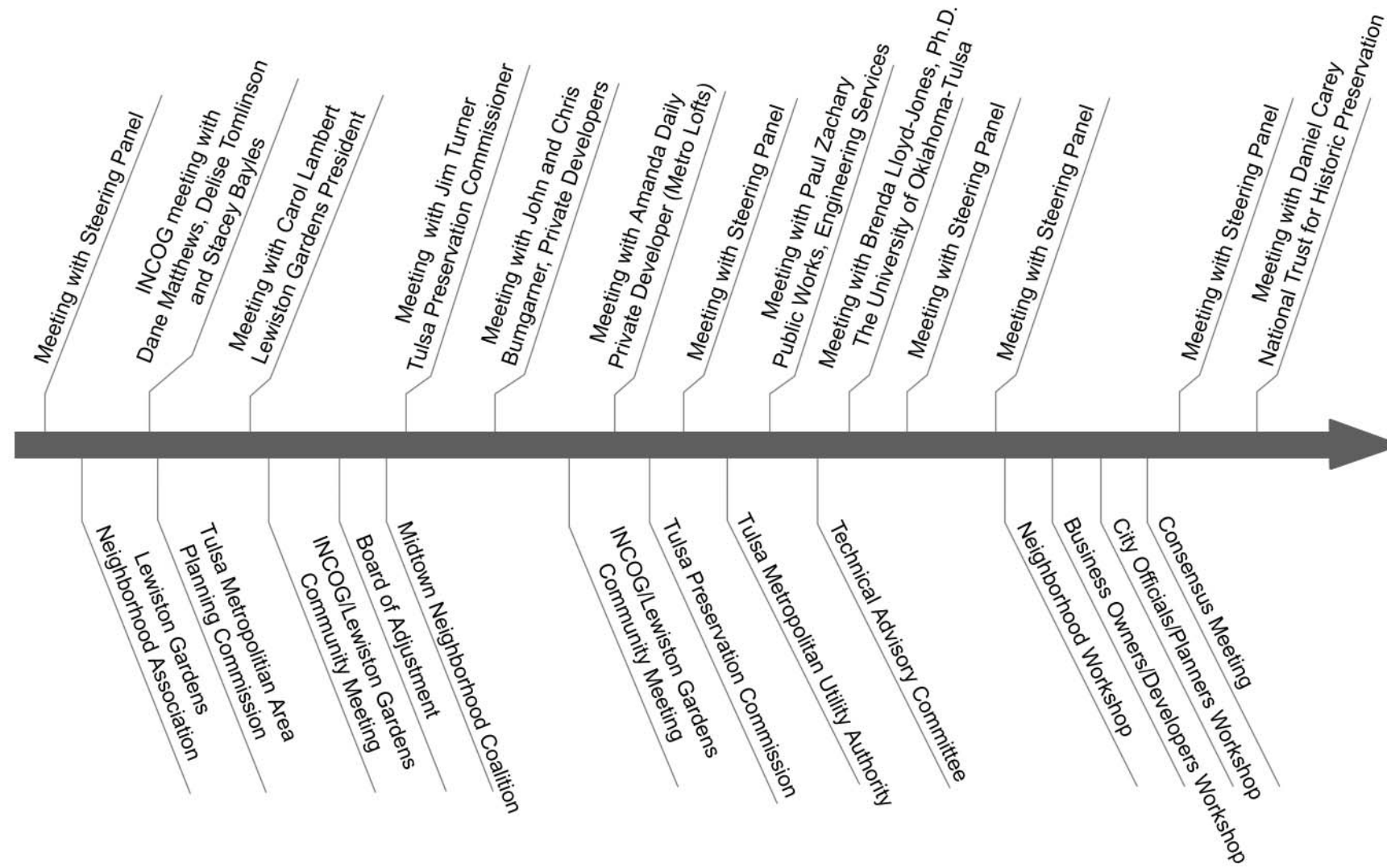

Public Meetings Attended

Process

Understanding the Development Process

After the initial meeting between the steering panel and the project team, questions arose regarding the process of development. Soon after, the students began attending a variety of public meetings and conducting personal interviews to better understand the process.



The diagram above was presented by Mr. John Bumgarner as a way to assess the development goals of the community. The diagram below is based on a conversation between Professor Schaefer and Mr. Patrick K. Treadway concerning the development process.

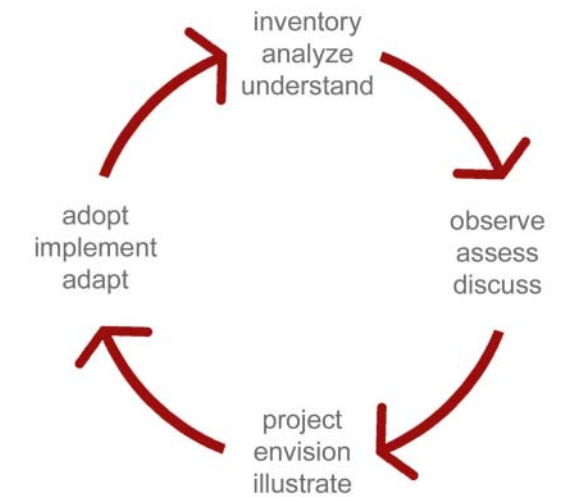

Process

What We Heard During Group Interviews and Public Meetings

- Planning and zoning codes are outdated and too complex.
- Both the general public and the development community lack convenient access to public work plans and standards.
- The lack of planning and/or an updated version of the comprehensive plan have frustrated neighbors, developers and city officials.
- Relations between the parties involved are often contentious.
- Neighborhood associations are not given enough time to communicate effectively with their residents when a request has been made to change zoning.
- Neighborhoods are too resistant to much of the changes that development brings.
- Neighborhoods feel their voice is not being heard by public officials.
- The creation of planned unit developments, historic preservation districts, and other special planning districts may be an indication of inadequate or outmoded conventional zoning.
- The PUD process is being misused.
- INCOG is understaffed and underfunded.
- Public works is underfunded and overextended; they try to compensate by demanding privately financed public infrastructure.
- City officials have been forced to act as referee and become reactive verses proactive.
- Inflexibility of some developers to vary from a set prototype or model that they have used previously leads to a changed urban pattern.
- Public meetings are often held at inconvenient times during the workday for residents to attend.
- Private developers feel the process takes too long because of the review procedures required by the many city departments.
- Developers can not predict expectations the city may require.
- Vehicle circulation and parking are major planning issues.
- City officials seem unfamiliar with alternative urban infill.
- Infrastructure development does not anticipate future development or coordinate with comprehensive planning and zoning designations.
- The current process of development is considered deficient by residents, developers and city officials.

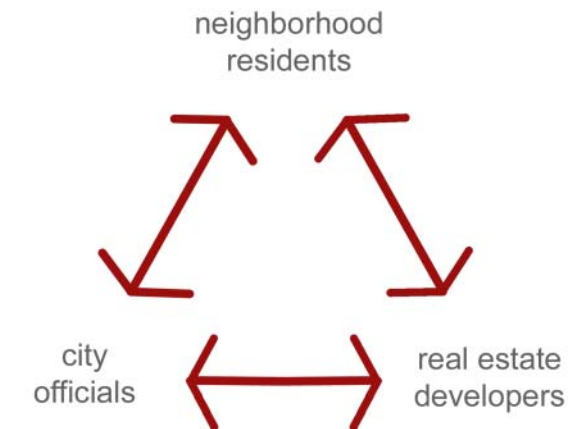

Sometimes a small issue can lead to unintended consequences.

Planning Game

Game Design and Model Construction

The students attempted to design street configurations that best represent what is found in the study area. These conditions include having lots with side yards that align, that run perpendicular, both with and without alleys. Once a layout was arranged that allowed for the various lot conditions and formed arterial streets bisecting the sheet laterally and longitudinally, it was plotted onto three 36" by 78" sheets, laminated to foam board, then attached to hollow doors to provide the base of the models. It was believed that a model of that size would provide enough area so that at least twenty people could play at a single board. The decision was made that a 1" equals 30' scale would allow for a large enough model to show the pattern of development as well as address building massing, planning and parking issues.

The game pieces were then constructed, starting with single family homes, by drawing simple geometric shapes in AutoCad, using a laser to cut sheets of black acrylic, sanding the pieces to form roof pitches, and assembling the components. Gameboard pieces were created to resemble single story bungalows, two-story foursquares, and detached garages. The commercial, multi-family residential, and structured parking pieces were a more direct process that required only drawing and laser cutting. Black acrylic pieces represented residential buildings, including the aforementioned bungalows and foursquares, as well as rowhouses/duplexes, four apartment flats, and six apartment corridor modules. Red acrylic pieces represented commercial buildings in different sizes: 2500, 5000, 7500 and 15000 square feet. Red pieces represent ground floor retail trade establishments, for example, a small restaurant or shop is 2,500 sq.ft., a larger restaurant or retail establishment like Panera Bread is 5,000 sq.ft., a commercial building like Walgreens Pharmacy or Office Depot is 15,000 sq.ft., and a Wal-Mart Neighborhood market is around 45,000 sq.ft. Other pieces in the development toolkit included: markers for drawing streets, setbacks and making notations on the gameboard; green tack pins to be used as trees or landscaping; surface parking pieces made from card stock; and bass wood screening walls. Small model cars were purchased to provide scale.

Playing the Game

The playing of the game evolved from the goals and objectives developed with the steering panel, class discussions, and preliminary testing runs with the second year studio students and the steering panel. The purpose of the game was to observe how the participants would develop

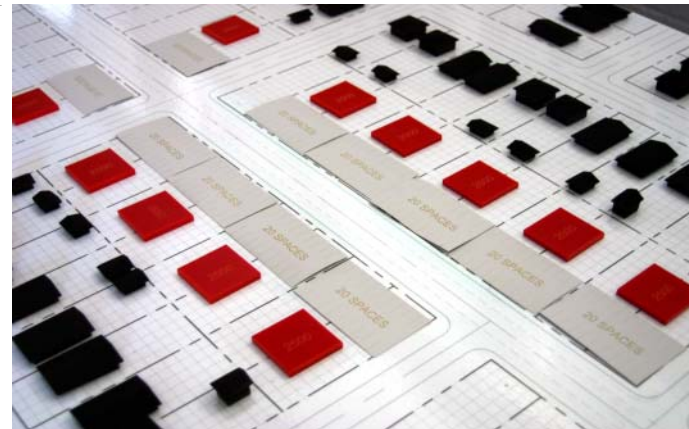

minimum development: 60 commercial modules
minimum parking: 20 spaces per module (ground floor)
10 spaces per module (upper floors)

commercial or mixed uses along the arterial street corridors. To begin the game, the lots along the arterials were intentionally left blank. All other lots were covered by single family housing. The constrictions placed by current zoning requirements were removed, with the exception of one important caveat—parking. Recognizing the city's current dependence on the automobile, it would be unrealistic to allow commercial development without placing any parking criteria.

A parking requirement was developed by averaging different use requirements based on the square footage of the development. In the preliminary stages of planning the game, a flat rate parking requirement of 20 spaces per 2500 sq.ft. commercial module, whether ground floor or upper floor, and two spaces for every new residential unit was established to offer a baseline. This rate was determined first by analyzing the study area's existing conditions in regards to parking proximity to commercial buildings and by analyzing current zoning requirements. The students calculated a measure based on the current commercial square footage to parking ratio (surface and structured) in the study area. They found that for every 147 sq.ft. of commercial building footprint in the study area there is 1 parking space. Using that data in the game play, a 2500 sq.ft. commercial module would require 17 parking spaces. When considering the zoning parking requirements it is necessary to examine an assortment of uses. For instance, restaurants require 1 parking space per every 100 sq.ft., which would translate to 25 spaces per module in the game. Night clubs require even more spots, with 1 space per every 75 sq.ft., which would be 33 spaces per

gameboard module. On the other end of the spectrum, medical offices have less of a need for parking and are required to have only 1 space per every 250 sq.ft. Antique stores require only 1 space per 300ft. Since the game did not suggest or restrict commercial use, it was necessary to determine a reasonable average that could also be added up easily during the game so participants would quickly know if they were in compliance with the requirement. The initial game requirement of 20 spaces for every 2500 sq.ft. of commercial space equates to 1 space for every 125 sq.ft. A suggestion from the steering panel lowered the total number of parking spaces required for upper floor commercial to 10 spaces for every 2,500 sq.ft. module, or 1 space for every 250 sq.ft. Recognizing that most upper floor uses tend to be offices, which are lighter in intensity, this was an appropriate change.

Parking pieces were provided in various forms of surface parking configurations, such as off-street lot, angled and parallel, as well as 60 space structured parking pieces that could be combined and/or stacked to form larger decks. Participants could include on-street, off-street, on-site and off-site parking in their required count to allow for even more flexibility. Underground parking was not permitted.



Planning Game

Playing the Game (continued)

The participants were welcome to develop the board however they wished — they could add or remove pieces already present, change street lane configurations, combine lots, draw parks, close streets or create new ones, build to any setback and to any height. Again, commercial uses were not specific and could encompass retail trade, office, and light industrial, and also be mixed with residential uses. The participants would have an hour to develop the area on the gameboard. Within that hour the first ten minutes were set aside for more instruction and questions, then thirty minutes to create development scenarios, followed by a ten minute huddle to discuss board development, and then the final ten minutes to finalize the scenario.

A minimum requirement of 150,000 sq.ft. of commercial development, or sixty 2500 sq.ft. modules, was established to ensure that some development would take place and address the first of our project goals (to examine the interface between historic neighborhoods and commercial redevelopment along arterial streets in Midtown Tulsa). The 60 module minimum was determined by using the following method. The students searched for the lightest possible commercial uses in the zoning ordinance, which happened to be light office. The maximum floor area ratio for light office set by ordinance is .3 (or .4 with approval from the Board of Adjustment). Considering each lot on the gameboard is 50' by 150', the area of each lot is 7500sf. The 2500sf module is equal to .3 of the lot, or in other words, one third of the lot.

With 97 empty lots along the arterials at the beginning of the game, the 60 module minimum would use less than two-thirds of the available lots, even if the group only built single story structures. From a density standpoint, the minimum commercial building requirement was similar to the density of the adjacent neighborhoods. For example, a typical block of 1500 sq.ft. homes on lots that are 7500 sq.ft. (50' x 150') has a .2 floor area value. The 97 vacant lots along the arterials add up to 727,500 sq.ft. The 150,000 sq.ft. commercial development minimum (60 modules x 2500 sq.ft.) would result in a .20 floor area value if the modules were situated on the vacant lots.

To enhance facilitation skills the students attended a training session led by Dr. Brenda Lloyd-Jones. She reviewed facilitation basics such as

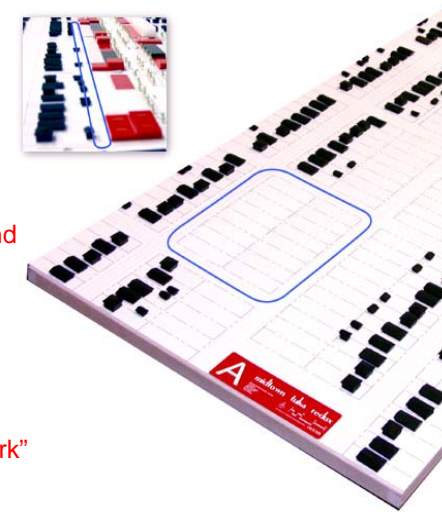
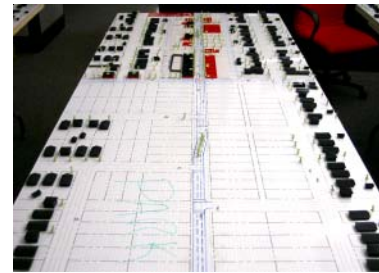

1. Design the transition zone behind the narrow lot development
2. Decide how to configure deep lot development
3. Address the need and function of the open space (noted as "park" on the gameboard)

logistics, roles, effective observation and intervention strategies and the importance of summarization. Due to the complexity of the game and the limited time, a student facilitator would assign members of each group specific roles, for instance: designing streets, placing new buildings, locating parking, planting trees, and representing the concerns of the existing neighborhood. Others participants would be generalists charged with looking at the big picture of what the specialists were doing. At least two members would be chosen to observe, record, and report what took place.

Community Workshops

The four community workshops were held on the University of Oklahoma campus. Over 2,000 invitations were sent to residents in the study area, business owners/developers, and public officials. The initial post card mailing was compiled from Urban Development files of property owners for the study area. It was then divided by residents and businesses addresses so that they could be sent for the appropriate workshops. Study area neighborhood associations also listed the community workshops on their websites and list serves as well as handed out flyers in their respective neighborhoods. Next, e-mails went out to professional groups including American Institute of Architects (AIA),

National Association of Industrial and Office Properties (NAIOP), and Building Owners and Managers Association (BOMA). Then public officials including City Council, Tulsa Metropolitan Area Planning Commission (TMAPC), Board of Adjustment (BOA), Tulsa Preservation Commission (TPC), City staff from Public Works and Urban Development were notified by postcard and e-mails. It was thought that by having an individual workshop for each of the groups above and then a consensus meeting of all participants at the end, the students could compare and contrast the comments and game playing of each group without any one group controlling the outcome, while providing all of the stakeholders an opportunity to contribute.

Each workshop began with an introduction to the project and instructions on using the model. In fact, the first hour of each workshop was dedicated to providing background information about the study area to offer a perspective of midtown Tulsa, as well as a slideshow to explain the purpose and rules of the game. Participants were then broken into groups and assigned to a gameboard to begin creating their scenario for midtown Tulsa. Student facilitators and Steering Panel members were at each table to explain the rules, organize the effort and answer questions, but not to decide the outcome of the game. The game itself provided participants a chance to debate, argue, and collaborate with others while attempting to create an ideal midtown. The game was played for one hour.

The third part of each workshop was an open discussion period where participants would describe their boards and then examine similarities and differences of the boards developed by the other groups. The students would record oral and written comments (noted on both flip charts and agendas), count each of the playing pieces, photograph each gameboard, and write brief summaries of the meetings.

(continued)

Planning Game

Community Workshops (continued)

The fourth meeting, the consensus workshop, focused on three issues that were raised at the earlier sessions—transitional buffers, 300' deep lot development, and open green space. To address these issues and depict what had generally been produced from the previous workshops, the rules for the game changed slightly. Half of the gameboard was

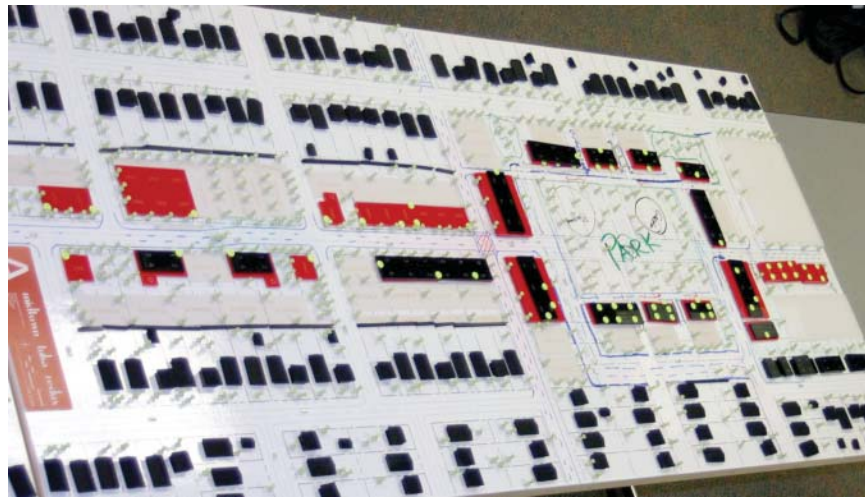

configured with various 150' deep developments that had been built many times by earlier participants. What needed clarity was how to deal with the transitional areas between the commercial development and the residential areas. The students asked the participants to focus on those transitional areas and depict buffer solutions. The other half of the gameboard was cleared to a depth of 300' on either side of the arterial to encourage participants to consider the conditions present with larger lot development. It is a reality that many commercial developments need a larger footprint than a 150' depth can provide. Also, there are currently parcels of that depth in midtown Tulsa waiting to be redeveloped. The purpose was to see how this group would choose to accomplish that task. Finally, green space and park land had been placed on five of the nine earlier boards, yet its purpose was often undefined. The students asked

the consensus meeting participants to define specific uses for that open space. Since the overwhelming board results from earlier sessions had not built buildings over three stories, a height limit of three stories was imposed. In addition, the minimum of commercial development rose from 60 to 82 2500 sq.ft. modules (205,000 sq.ft.), which was the mean average of commercial development from the previous workshops.

Limitations and Qualifications

As the weeks progressed, limitations and qualifications of the gaming process became apparent. Time, space and previous commitments restrained some of the participants from a fuller understanding of the game. The three hour workshop format did not provide the time for in depth training of participants in many aspects of planning and real estate development. Not all participants could commit to a three hour workshop and left early.

The abstraction of the gameboard compared to the earlier description of the study area centered on 15th and Utica caused confusion and made it difficult for participants to treat the game as an abstraction. Participants repeatedly insisted on knowing whether this arterial was a particular street or another. Other participants struggled with how the game board was set up and felt uncomfortable with not having an orientation to downtown. By having the arterial streets clear at the beginning of the game it was thought that new development would be easier to obtain versus removing properties. It was suggested later, that the gameboard should have been set up with a "real life" mix of residential and commercial development even along the arterial streets. Then participants would have to remove existing structures in order to accomplish their development. Therefore the consequences of the development could be visualized and quantified.

The scale of the pieces served well for planning and massing but lacked detail for architectural style.

Below are rules of thumb and issues to consider that were presented to the workshop participants before playing the game (Red text added to show additional comments for Consensus Workshop).

some rules of thumb...

- provide 20 parking spaces for each ground floor commercial module
- provide 10 parking spaces for each upper floor commercial module
- 2 parking spaces should be provided for each new dwelling unit
- retail establishments prefer one main entrance
- retail establishments are usually on the ground floor
- driving lanes in streets are typically 10' to 12' wide
- minimal sidewalks should be 6' to 8' wide
- structured parking must be at least two bays wide

some things to consider...

- lots may be merged to make bigger parcels for development
- existing houses may be removed for development or parking
- commercial uses may include retail trade, office, and light industrial and be mixed with residential uses
- building height limit is 3 stories
(4 levels for parking)
- build-to line on the arterial streets = 0' to 10'
- streets can be 2 or 3 lanes, with or without medians
- most surface parking must be placed in the rear or interior of the lot

Agenda

Midtown Tulsa Redux Urban Design Workshop Agenda

Introduction – 10 minutes

- Welcome – Professor Schaefer
- Town Hall Consent Announcement
- Introduction of Students and Steering Panel
- Purpose and Goal of Today’s Meeting:
“To explore and discuss how redevelopment could occur along arterial streets adjoining older, historic midtown Tulsa neighborhoods.”

Presentation of Research – 20 minutes

- Purpose and Goals of the Study
- Project Schedule
- Role of the Steering Panel
- Pilot Study Area
- Photo Documentation
- Mapping Inventory

Instructions for the Group Planning Exercise – 10 minutes

- Description of the Planning Models and Playing Pieces
- The Rules of the Game
- How to Play the Game
- Examples of Planning Scenarios

Group Planning Exercise – 60 minutes

- Student Introduction – 10 minutes
- Scenario Creation – Game Playing – 30 minutes
- Huddle – 10 minutes
- Finalize Scenario– 10 minutes

Break – 15 minutes

- Explanation of Scenarios by Group Spokespersons – 3 x 10 minutes = 30 minutes
- Discussion of Similarities, Differences and Patterns – 30 minutes

Closing – 5 minutes

- Revisit Project Schedule – What is Next?
- Summarize Information
- Submit Findings and Recommendations
- Next Scheduled Meeting



Midtown Tulsa Redux

Neighborhood Workshop

- Invitations sent to neighborhood residents 1,500
- Neighborhoods in attendance Yorktown, Swan Lake, Gillette, Lewiston Gardens
- Number of residents in attendance 70
- Steering Panel members in attendance 10
- Students in attendance 5
- Boards played 3 (A, B & C)

Developers/Business Owners

- Invitations sent 300
- People in attendance Area Developers, Cherry Street Merchants, Architects, Contractors
- Number in attendance 18
- Steering Panel members in attendance 10
- Students in attendance 5
- Boards played 2 (A & B)

City Officials/Planners

- Invitations sent 50
- People in attendance City of Tulsa Planners, Engineering Dept., Utilities Dept., Building Plans Examiners, Tulsa Preservation Commission, INCOG, City Counselors
- Number in attendance 28
- Steering Panel members in attendance 10
- Students in attendance 5
- Boards played 3 (A, B & C)

Photos of the participants

Neighborhood Workshop

Board A

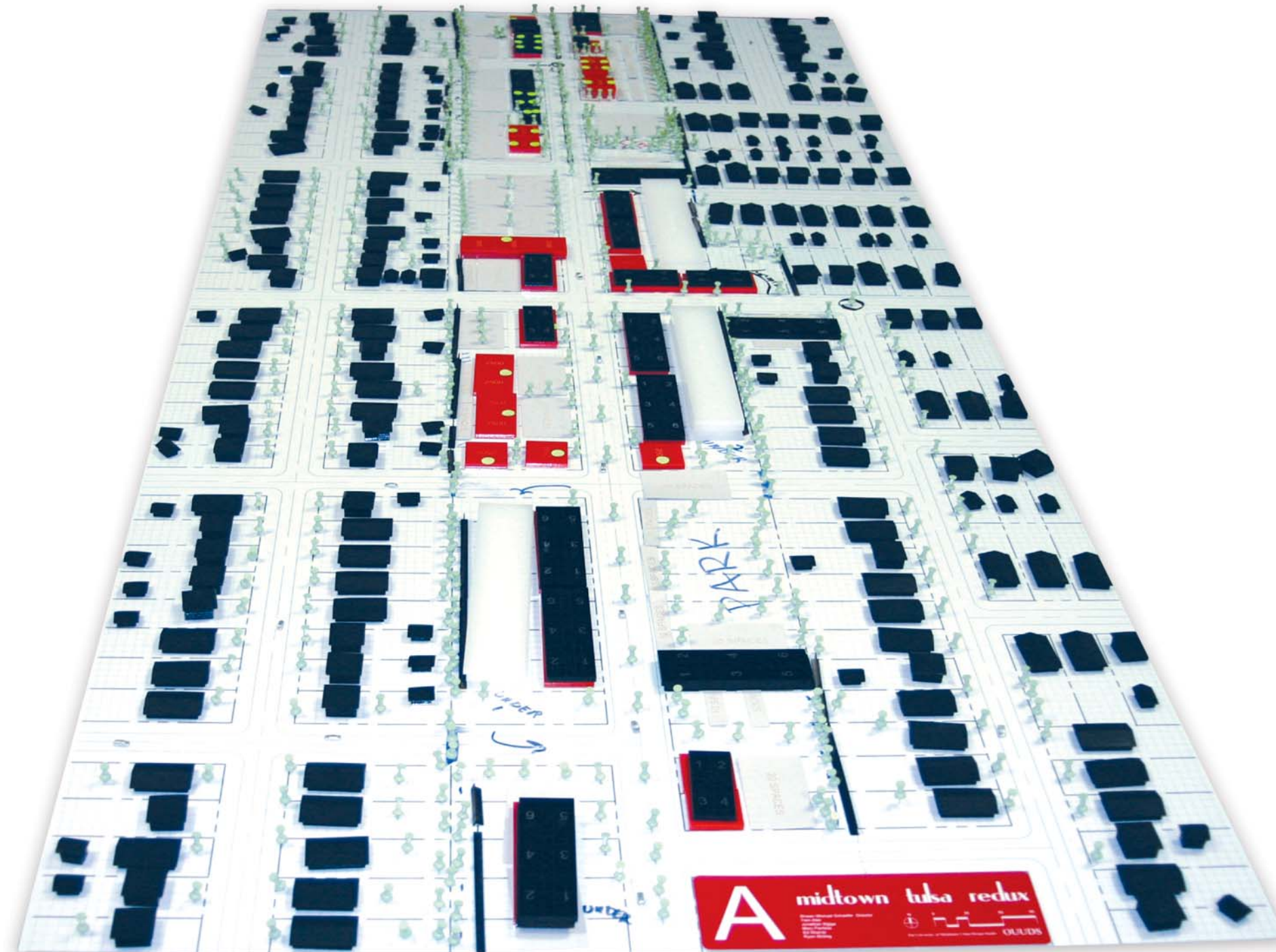

Transitions between commercial and residential development was the focus of this board. If parking is to be placed near residences, a buffer is important. Also having mixed used on the arterials will provide a nice variety of building types. Medians with trees and dead-end streets gated were also used as traffic calming where commercial and high dense residential abuts single family residential. There is a need to minimize the number of parking spaces required. No large signage, small retail and offices, no big box retail and underground utilities are a must in this area. Lastly, managing light and noise pollution from large parking lots was also found to be an important design consideration.

Neighborhood Workshop

Board B

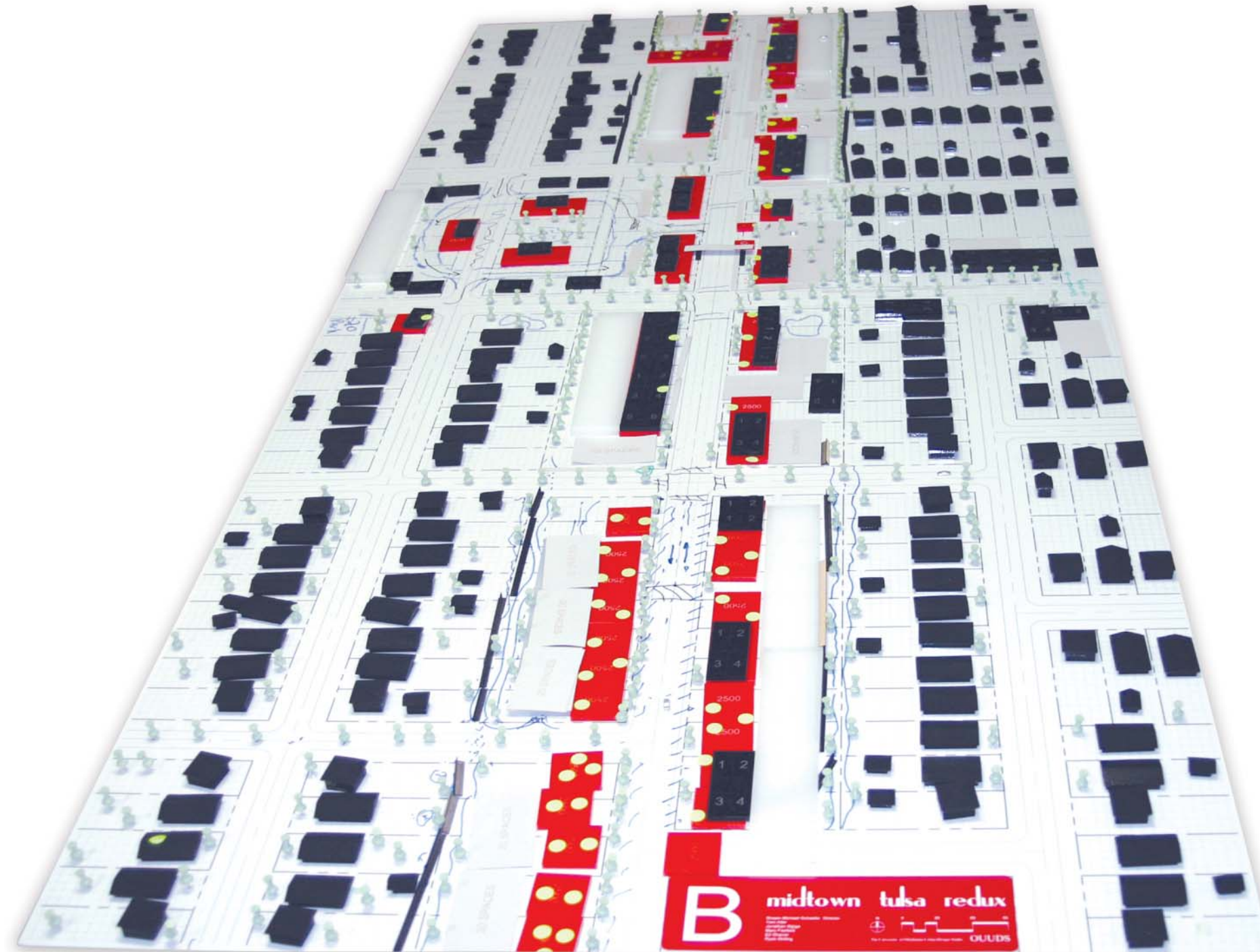

This team focused on shallow lot development along the main arterial with extensive use of screening to shield the neighborhood from the commercial development. Some mixing of uses with retail on the bottom and apartments above added height to the street frontage. Lanes were narrowed from four to two in areas to provide for on street parking and as a traffic calming device; in addition abundant use of trees, multiple sidewalks, and a bike trail help create a multimodal area. Both surface and structured parking were provided although we discovered later that single bay parking garages are not functional without an additional ramping system.

Neighborhood Workshop

Board C

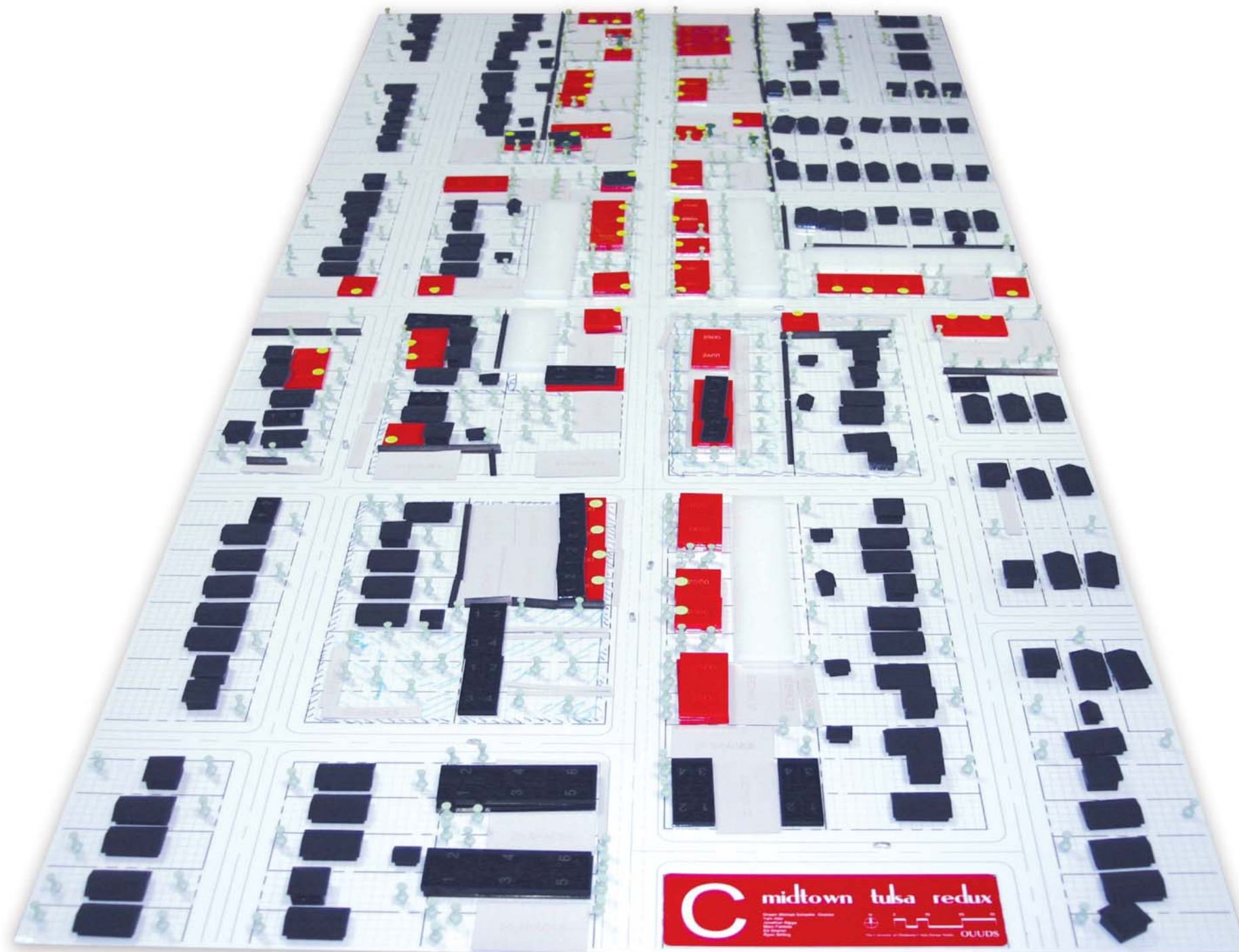

The board was developed to minimize the impact on the surrounding neighborhoods. Building heights were restricted to no more than two stories. Alleys were removed from the board due to safety concerns and one residential street was closed to prevent overflow parking on neighborhood streets.

Neighborhood Workshop

Board A



A1

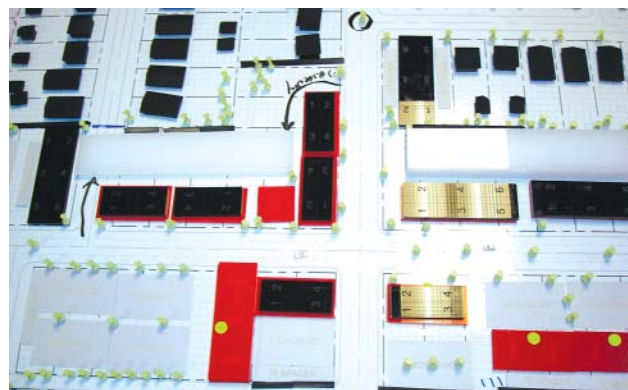

A2

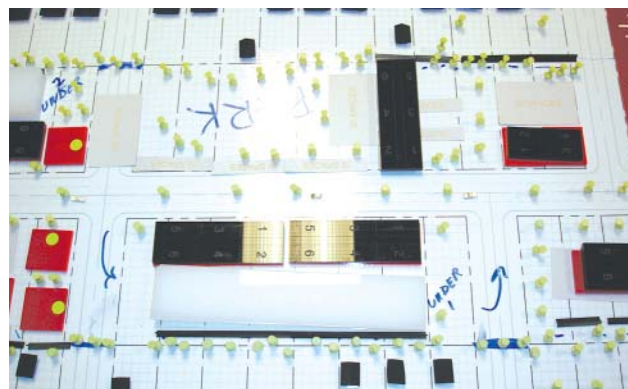

A3

Board B

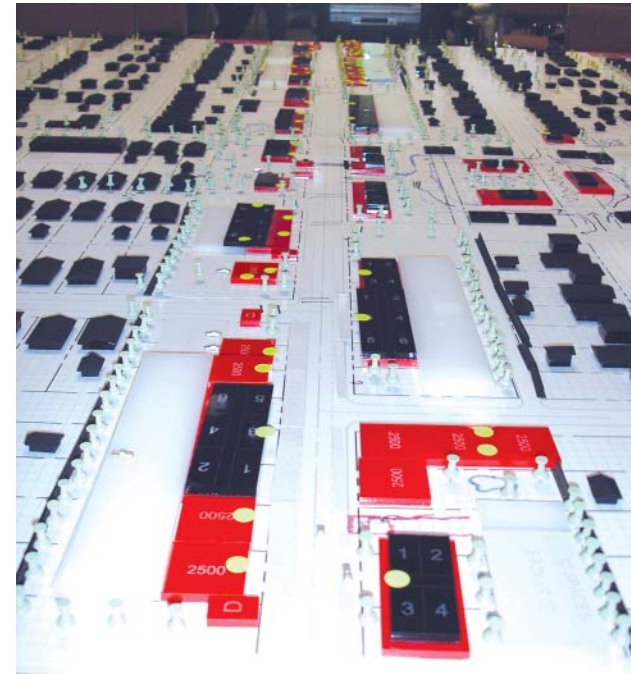

B1

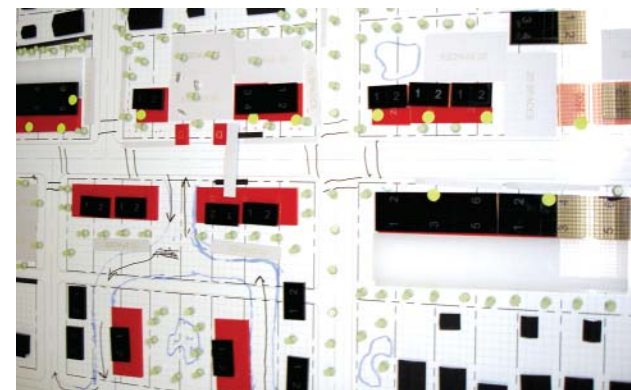

B2



B3

Board C

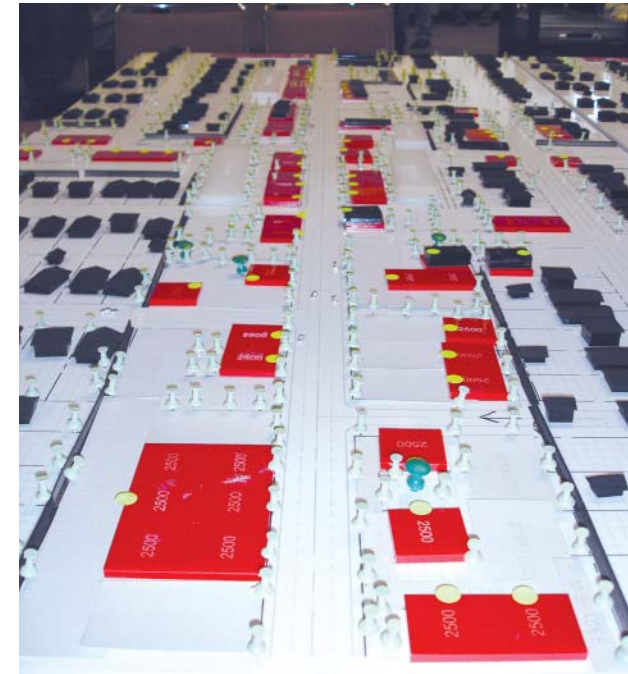

C1

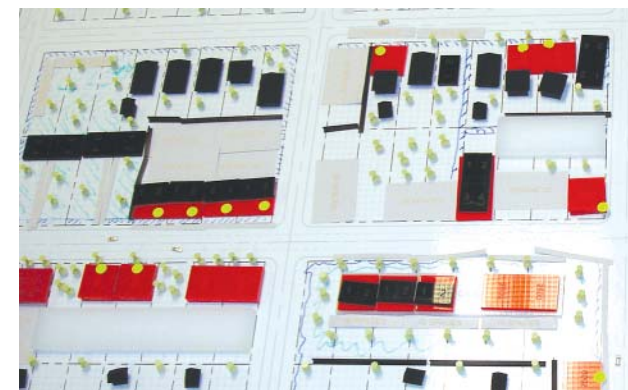

C2



C3

Gameboard Details

- A1** Higher density along main arterial corridor with landscaping.
- A2** Main arterial intersection showing mixed use development with commercial on the ground floor and residential above.
- A3** Arterial street depicting transitions between residential and commercial development. Single family homes buffered with a tree lined path and fence abutting a parking garage separating the mixed-use development (multi-family above commercial).

- B1** Higher density commercial along arterial corridor buffered by structured parking garage from the neighborhood homes.
- B2** Mixed use development with retail on the ground floor and housing above.
- B3** Multi entrances to the commercial units apart from the service entrances in the rear of the buildings. Also shown is continuous fencing with heavy landscaping for buffer between commercial and residential.

- C1** Looking up the long arterial street, showing mostly one and two-story structures.
- C2** Main arterial intersection, looking up the short arterial. Mixed-use development fronts the arterial, along with new multi-family housing set back from the street with green space in front and behind (left side of photo). An “artist enclave” mixed use development is pictured in the top right. It is comprised of single-family “live-behind” housing units with artist studio space, green space, and a network of pedestrian paths.
- C3** Long arterial street running left/right. Note the closing of the residential street in the top right of the photo, as well as the closure of the alley. In the middle right, a 15,000 square foot commercial space with parking and primary entrance in the rear.

Neighborhood Workshop

Flip Chart Notes



Group A

1. Parking if placed near residences, a buffer is important.
2. Underground parking not allowed due to high cost.
3. Residential housing with commercial on the bottom floors.
4. Medians with trees.
5. Dead-end streets – gated. Where commercial and high density residential abuts single family residential.
6. Need to stack commercial development.
7. Need for attractive surface parking buffer.
8. Need for trees throughout parking lots.
9. Need to change the number of parking spaces required (minimize).
10. No big signage.
11. Small retail and offices, no big box retail.
12. Need for mixed commercial / residential small shops.
13. Minimize surface parking.
14. Noise control (no 4am dumpster).
15. Underground utilities.
16. Manage light pollution from large parking lots.
17. Shared parking.
18. Avoid alleys, problematic.

— Similarities
— Conflicts



Group B

1. Commercial abutting residential adversely impacts residential- Solution: create landscape walking path between uses, borrowing R.O.W. from both commercial and residential owners.
2. Heavy landscaping need for transition area (buffer).
3. Higher density commercial along corridor (properly buffered) with rear structured parking is preferable to acquiring residential property deeper into the neighborhood for lower density commercial.
4. Two lane streets (arterials) with on-street parking slow traffic speeds and makes commercial more pedestrian friendly.
5. Encourage historic design with all new commercial and residential construction.
6. More boulevards.



Group C

1. Vacate alleys.
2. Pedestrian scale development.
3. Why commercial development in a residential district?
4. Mixed used development.
5. Street closing in residential from the arterial street.
6. Live, work and play development in a residential district (artist – enclave village).
7. Need for sound and light buffers using landscaping materials.
8. Debate surface parking vs. structured parking – structured preferred (max. height 2 stories).
9. Height impact on adjacent structures and residential.
10. Bury power lines.
11. Heavily landscape for buffering.
12. Arterial are four lane in both directions.
13. Relations to residential property values.

Developers/Business Owners

Board A

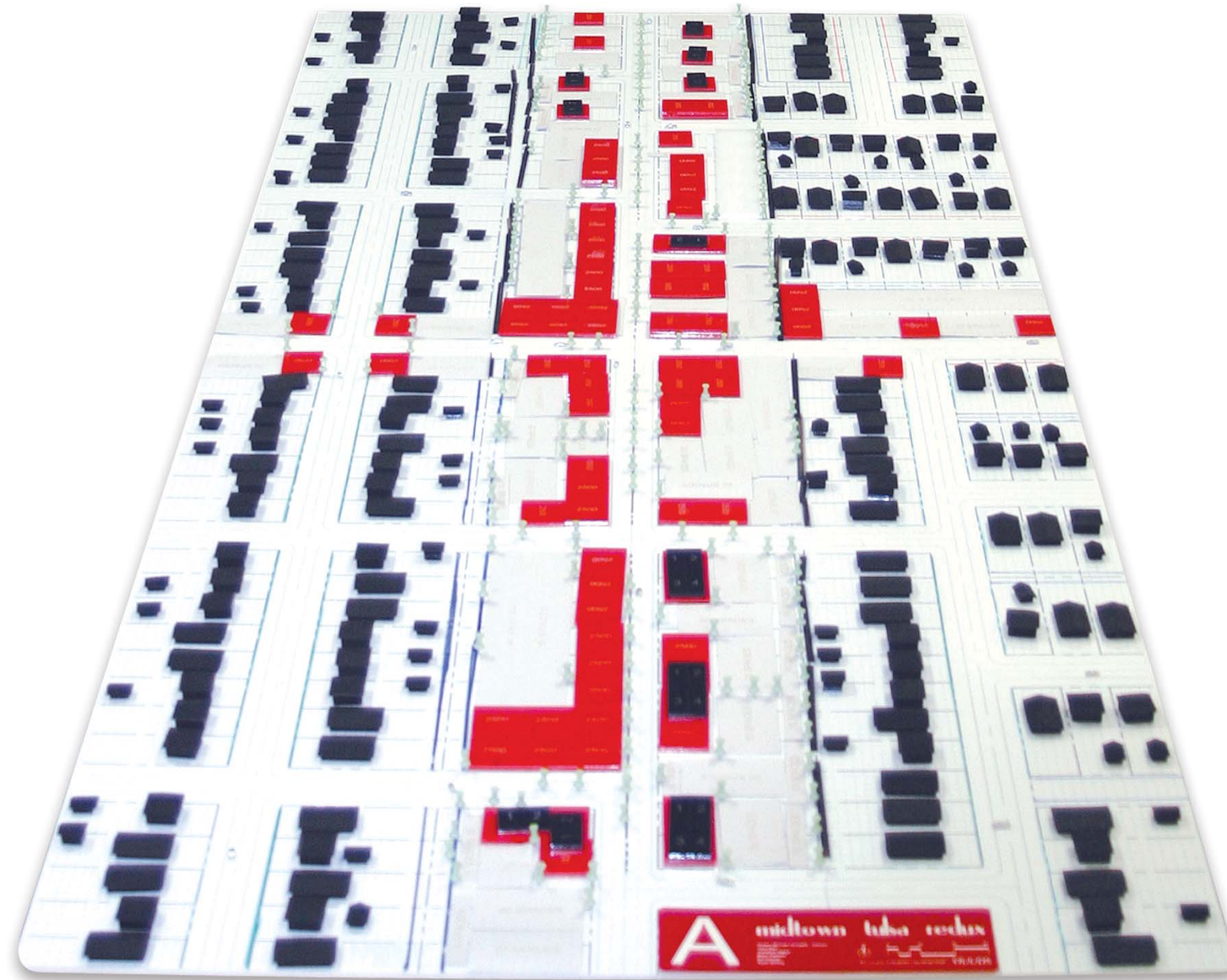

Many design concepts were considered in this group. One of which prevented bottlenecks in the street by providing wider streets on arterials. Also, generous sidewalks connecting residential to commercial were also part of the design. Parking was strategically placed at the rear of the building for the most part to keep all the commercial development up front. Underground utilities and alleys access to residential were also an important part of the scheme. Finally, the idea was to create an urban village with street frontage primarily commercial along arterial (one in particular) because there seems to be a trend towards multi-level multi-use buildings and parking within one or two blocks from the intersection of arterials.

Developers/Business Owners

Board B

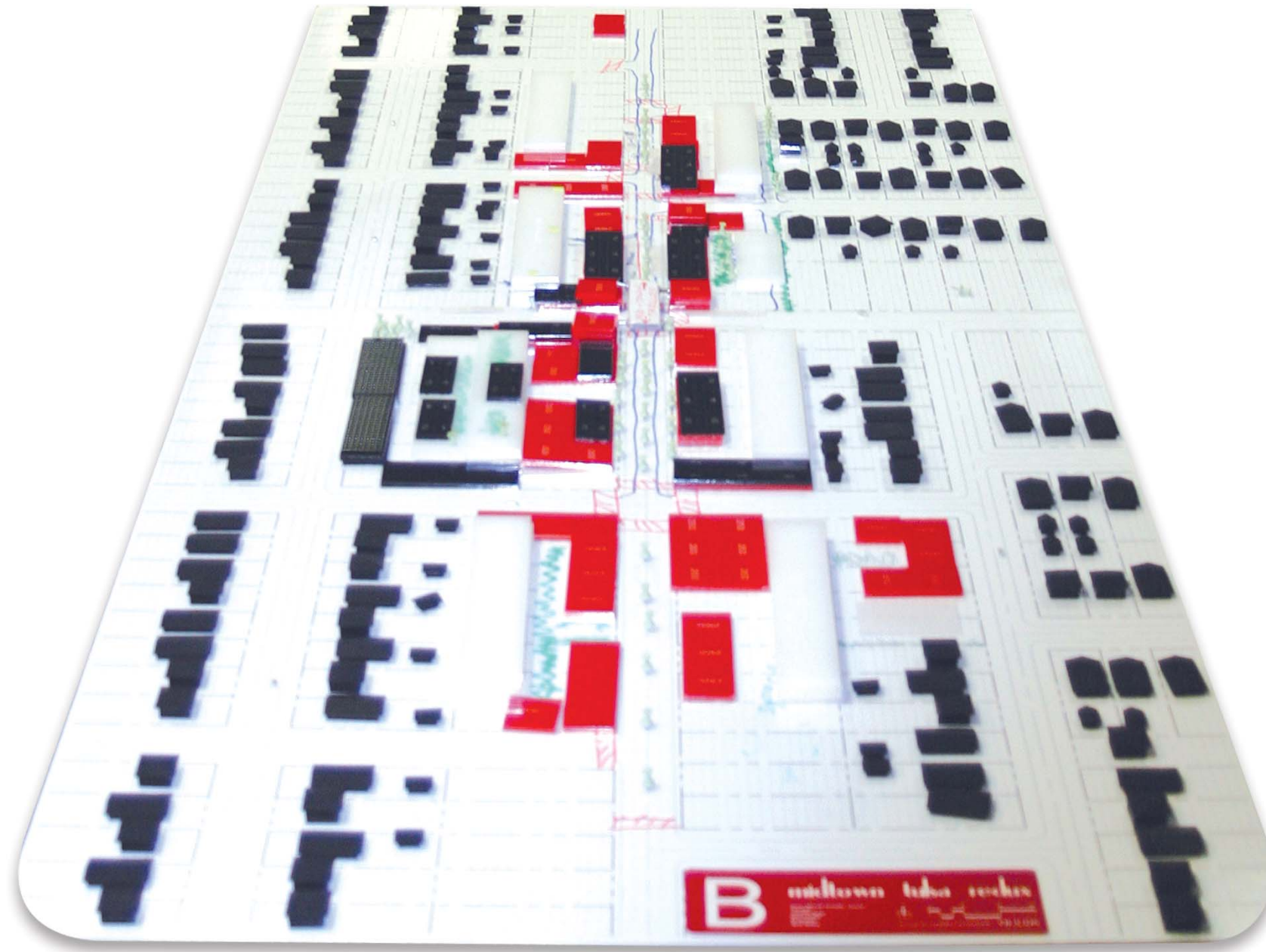

In creating this board an emphasis was placed on establishing a high density yet pedestrian friendly area with multi-story buildings, many mixed use in nature, being brought to the front of the property line. The street configuration was altered to two lanes, although they did create a bike lane and crowned crosswalks. Discussion lingered regarding time limited on-street parking because they would prefer not to have meters yet wanted to offer some store front parking. The business owners also suggested a privately owned trolley to shuttle customers from the structured parking in back to the retail stores along the arterial. The group felt that the parking structures could also serve as a buffer to the adjacent neighborhoods although they emphasized the necessary mutually beneficial dynamic between the two in the area they designed. As a point of reference this board was not finished at the end of the gaming time and this undoubtedly skews some of the statistical measures based on the density of half of the board completed.

Developers/Business Owners

Board A



A1

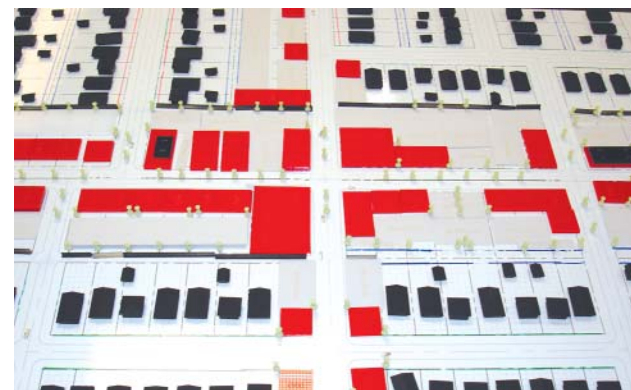

A2

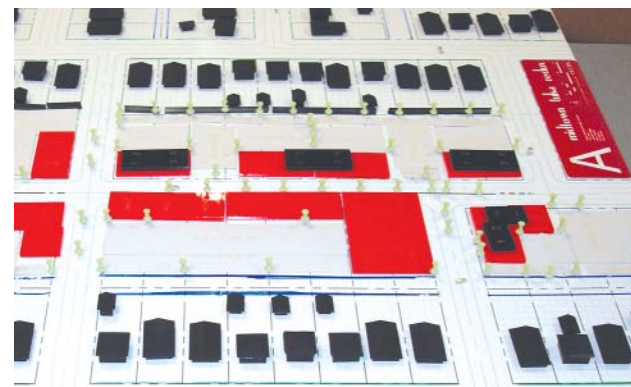

A3

Board B

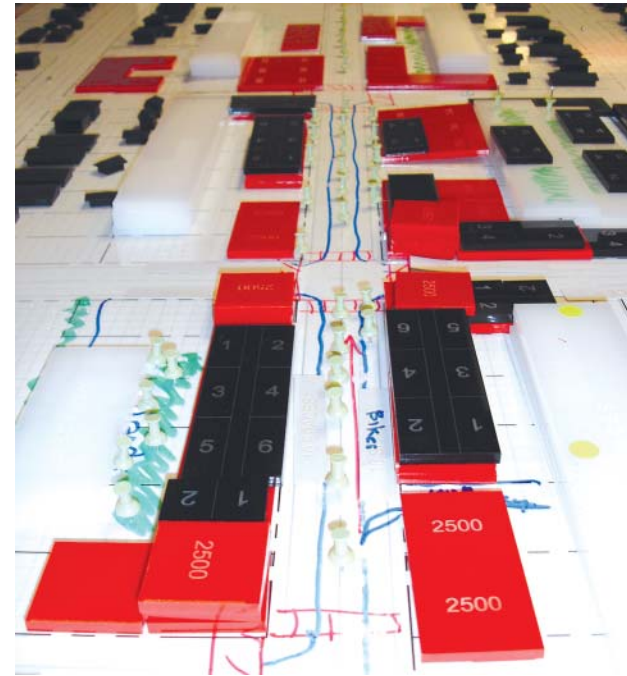

B1

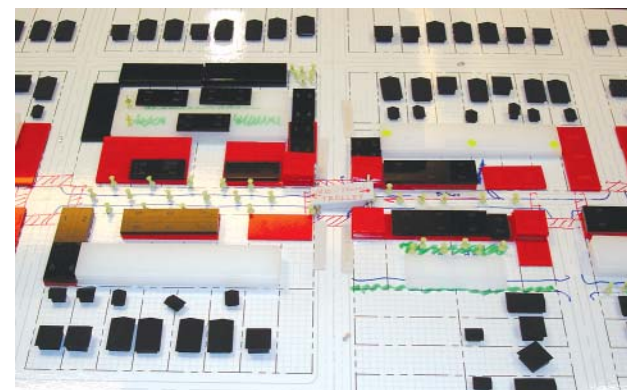

B2

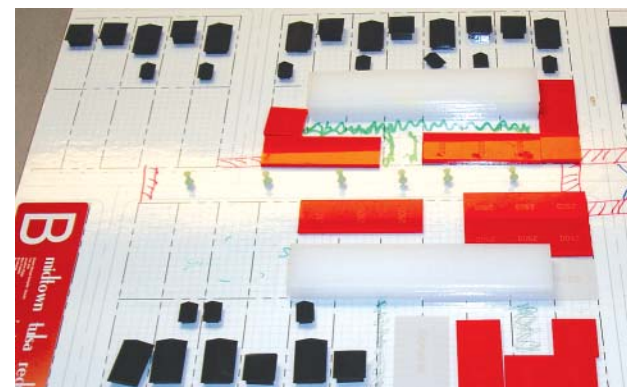

B3

Gameboard Details

- A1** Higher density commercial buildings lined up along both sides of a treed boulevard. Some mixed-use development setback slightly from the arterial street provides an opportunity for both landscaping and limited parking.
- A2** Zero setback commercial development along both sides of the arterial street with parking and service entrance at the rear.
- A3** Commercial uses on the ground floor with multi-family residential above. These buildings are seen as a mirror continuation in scale of the opposing commercial buildings.
- B1** The creation of a destination arterial with both shallow and deep lot development constructed to the “build to” line. The main arterial street has been altered to allow for a bike lane and on-street parking. This group suggested a merchant owned trolley to transport customers from structured garages behind the development to the businesses along the frontage.
- B2** Eight established homes were removed to allow for the mandated parking requirement connected to the denser development constructed. Multi-family residential built on smaller lots to replace the older homes and inturn buffer the parking structures from the current neighborhood.
- B3** Moving away from the main intersection, development becomes less intense single story. The three level parking deck was constructed to provide for adequate parking for the district as a whole.

Developers/Business Owners

Flip Chart Notes



Group A

1. Should have a warm and cozy feeling.
2. Bottlenecks in the street are a concern.
3. Desire for wider streets on arterials.
4. Left turn lanes necessary?
5. Idea of adding a fifth lane?
6. Need for sidewalks to connect residential to commercial.
7. Parking on the side or at the rear of buildings.
8. Underground utilities.
9. Want alley access to residential. Alleys provide play areas and rear access.
10. Game board doesn't take into account the topography or highways.
11. Idea of an urban village with street frontage primarily commercial along arterial (one in particular).
12. Trend towards multi-level multi-use buildings and parking within one or two blocks from the intersection of arterials.
13. Most upper floor residential not at intersections of arterials (about two blocks away).
14. Sidewalks along residential streets.
15. Median along main arterials with landscaping.
16. Trees used as buffers in parking lots and also to create plazas.



Group B

1. Pedestrian is the emphasis.
2. Parking at arterials present problems during lunch hours (premium). Ideas of share parking.
3. On-street parking results in 4 lanes less 2 lanes equals more parking spaces available and also traffic calming.
4. Commercial along arterials with parking at the rear.
5. Sidewalks.
6. Highly visible crosswalks
7. Narrow streets to 2 lanes.
8. Slow down traffic to respect pedestrians.
9. Flashing light warning and other warning signs for pedestrian areas.
10. Planted medians.
11. Cobblestone pavers.
12. Bike racks.
13. No curbs, bollards instead.
14. Residential on top of parking structures.
15. Angled parking.
16. Mixed used development / multi-story.
17. Well-lit, secure passageways from commercial to large parking areas.
18. Establish design guidelines for transitional spaces.
19. Cherry Street merchant's trolley which runs up and down the arterial. Privately funded and free rides (maybe fee with parking ticket).



GROUP A



Ed Sharrer



GROUP B



Ryon Stirling



Yani Aller

— Similarities
— Conflicts

City Officials/Planners

Board A

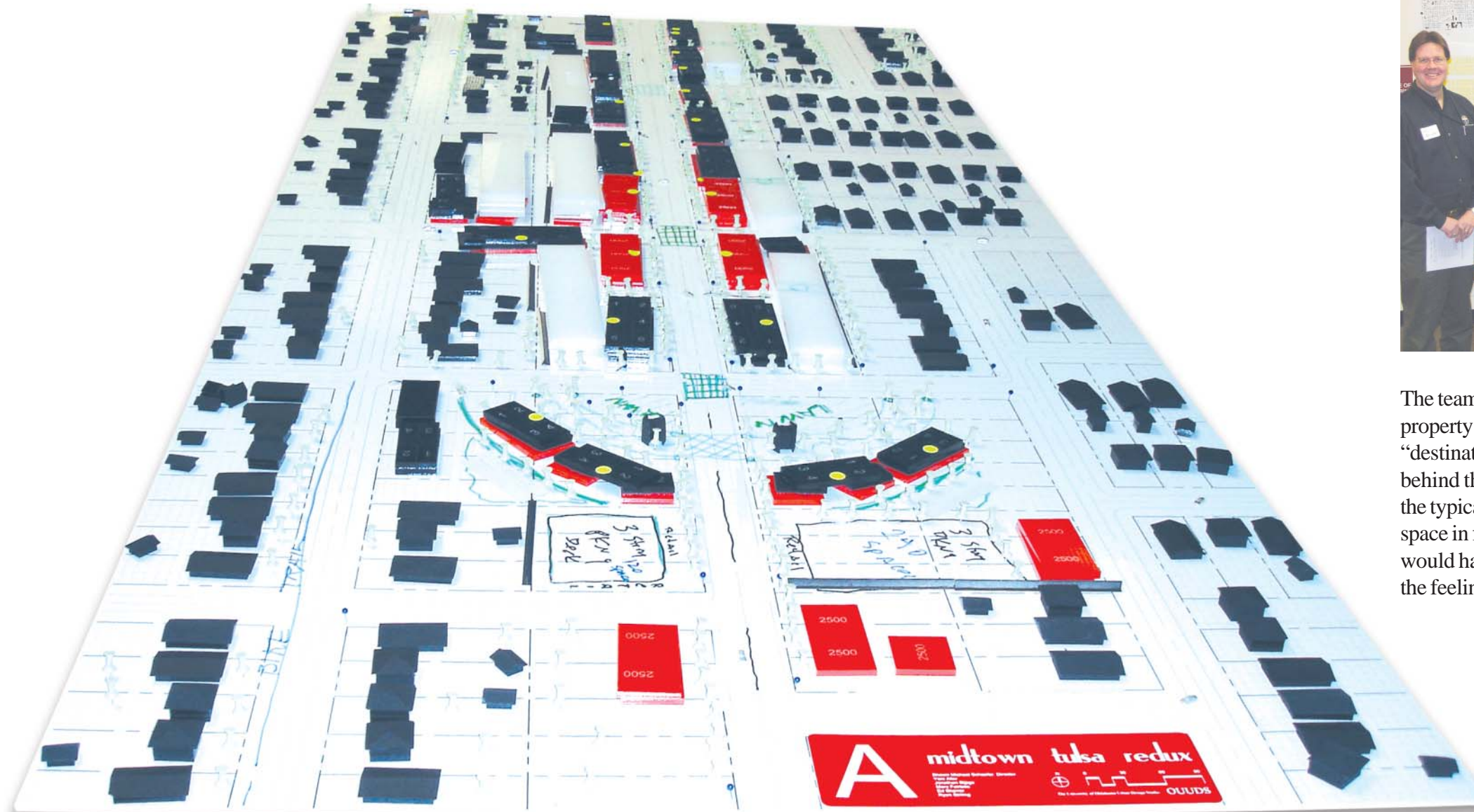

The team created a medium density development along the arterials built to the property line giving the board an updated urban identity with the idea of being a “destination area.” The necessary parking was provided by structured parking behind the two and three story development. As a change of pace, they altered the typical grid pattern by establishing a mixed use semi-circle with some green space in front of the buildings. It was discussed that, if time had allowed, they would have mirrored the image on the other side of the board to approximate the feeling of a town square.

City Officials/Planners

Board B



Mixed-use redevelopment was one of the main focuses on this board. Another main design idea was to establish nodes for commercial development with highest and most intense use. Transitions from commercial to residential areas brought about design considerations for a path between the two. This path consisted of landscaping, trees and fences as a buffer. Multi-family residential along the perimeter of single family residential was also designed as a buffer. For traffic calming, diagonal parking brought both a nostalgic feeling and traffic calming.

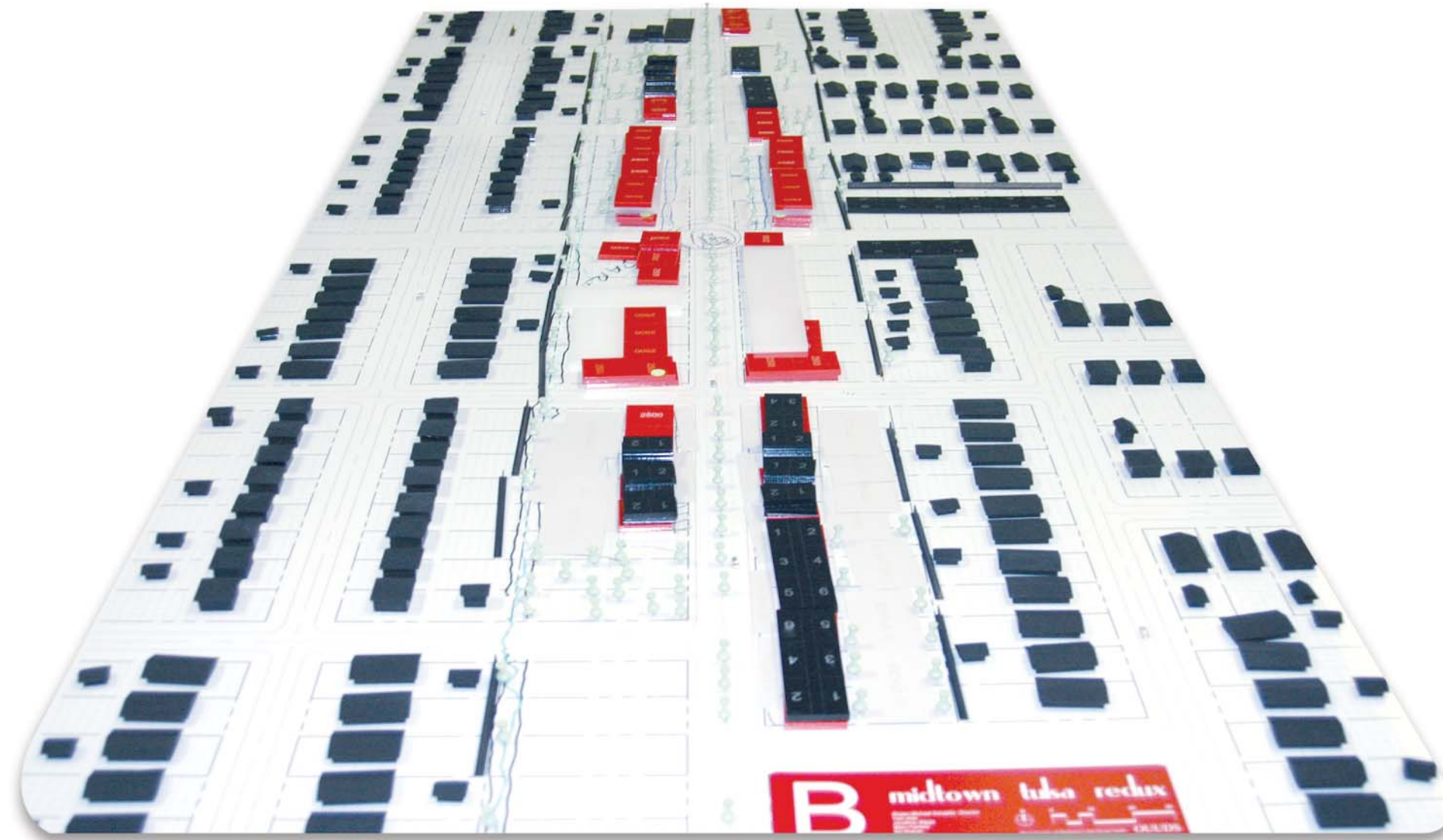

City Officials/Planners

Board C



The board was developed to calm traffic and provide for pedestrian circulation. A network of pedestrian alleys (possibly a bike path or even a right of way for a public trolley line) was created between the commercial development and the neighborhoods. Trees were planted in abundance, including on rooftops to increase the permeability of the area. The board included several mixed-use buildings and new residential construction.



City Officials/Planners

Board A



A1

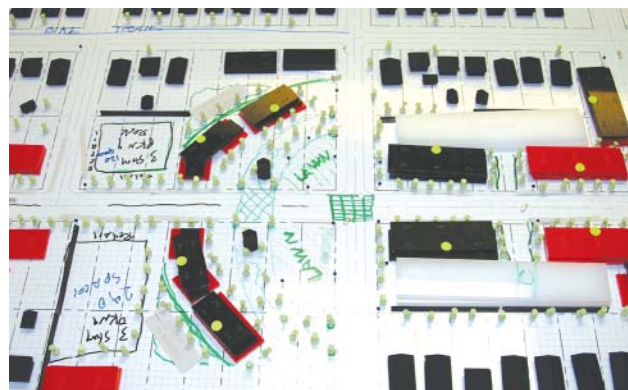

A2



A3

Board B

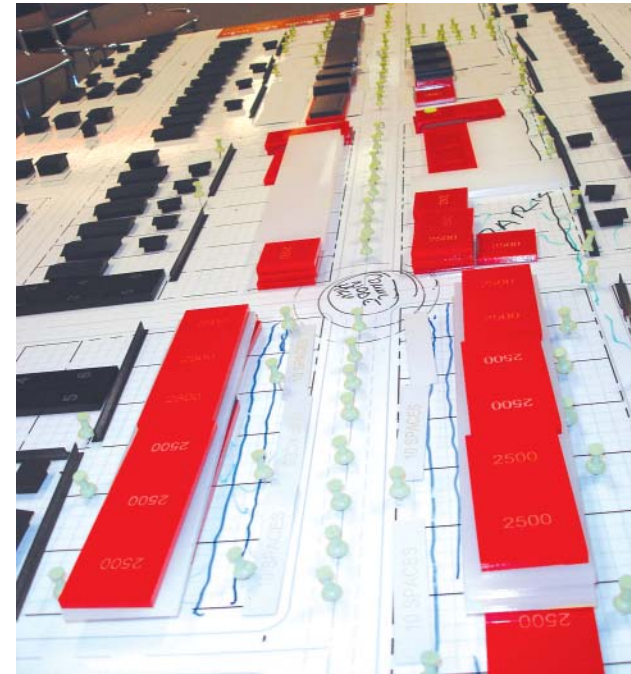

B1



B2

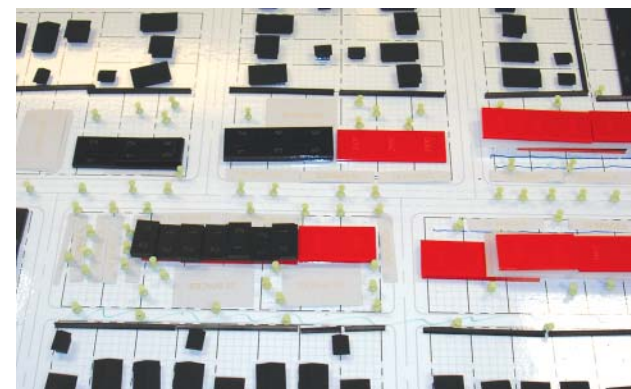

B3

Board C



C1

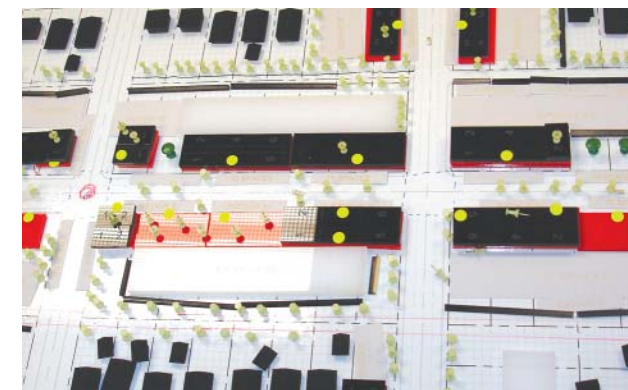

C2



C3

Gameboard Details

- A1** Depicts a dense concentration along the arterial with a transitional oval that was meant to be replicated on the opposite end of the board creating a conceptual “town square.”
- A2** A close up of the oval ,which includes a park, accessible to nearby residents and employees of the district.
- A3** An image of the main arterial intersection buffering the higher intensity commercial/residential space and the neighborhood with structured parking as well as screening walls and trees.

- B1** A three story structure with two commercial levels separated by a level of parking in the middle is in the foreground of the photo. Trees planted in the median, on street angled parking. The blue lines represent sidewalks encouraging walkability.
- B2** The main intersection shows that the development is only one lot or 150’ deep and is being buffered by trees, screening walls and a small pocket park.
- B3** The use of surface parking behind the buildings with a heavy planting of trees and use of screening between the established residential area and new mixed use development on the arterial.

- C1** Abundance of trees encircle narrow lot development along the arterial street with the buildings set on the property line and parking available behind.
- C2** The main arterial intersection features mixed use development with apartments above ground-floor commercial space.
- C3** A street narrowed to two lanes with angled parking brings people to new gated community adjacent to a small park.

City Officials/Planners

Flip Chart Notes



Group A

1. No Big Box retail.
2. Residential on top of retail.
3. Patterned intersection treatment.
4. Remove some structures for new development.
5. Increase housing density in neighborhood.
6. Structured parking provided.
7. Heavily landscaped arterials and residential streets.
8. Bury utilities.
9. Some concern that there is too much retail and commercial.
10. Concern about orientation of commercial to residential.
11. Want some 'small' retail in the neighborhoods.
12. Parking requirements sometimes 'stops' small retail from happening.
13. Some non-traditional new development orientation on streets.
14. City subsidized parking needed.
15. Add parks and green space
16. Coordinated street lights
17. Commercial façades should be attractive
18. Design guidelines for arterials (materials and design).
19. Trolley for people to move around.
20. Walkability is important and Bike trails.
21. On street parking on arterials if possible (may have 0' setbacks and sidewalks).
22. Easements on private property.



Group B

1. Mixed-use redevelopment.
2. Establish nodes for commercial development with highest and most intense use.
3. Establish development areas delineating commercial from residential – buffer with landscape.
4. Multi-family residential perimeter of single family residential.
5. Diagonal parking for both a nostalgic feeling and traffic calming devise.
6. Use alleys as green-belt separating development areas (landscaped with pavers, trees).
7. Developers required for purchasing and maintaining greenbelt areas.
8. Add tree lined medians.
9. Advocating for a variety of building heights and uses.
10. CBD vs. Traditional pattern of development
11. Linear development



Group C

1. Trolley system automated (supervised from a remote site).
2. Tree-lined alleys to divide residential from commercial.
3. All parking lots planted.
4. Trees obstruct signage and views of buildings
5. All streets tree-lined
6. Some type of historical marker in select intersections (arterial to residents)
7. Fountains
8. New residential subdivisions
9. Parks
10. Barriers/Tree buffers for parking lots.
11. Bury Utilities.
12. Sidewalks on all streets
13. One concept: trolley in alley to loop.

— Similarities
— Conflicts



Midtown Tulsa Redux

Consensus Meeting

Board A

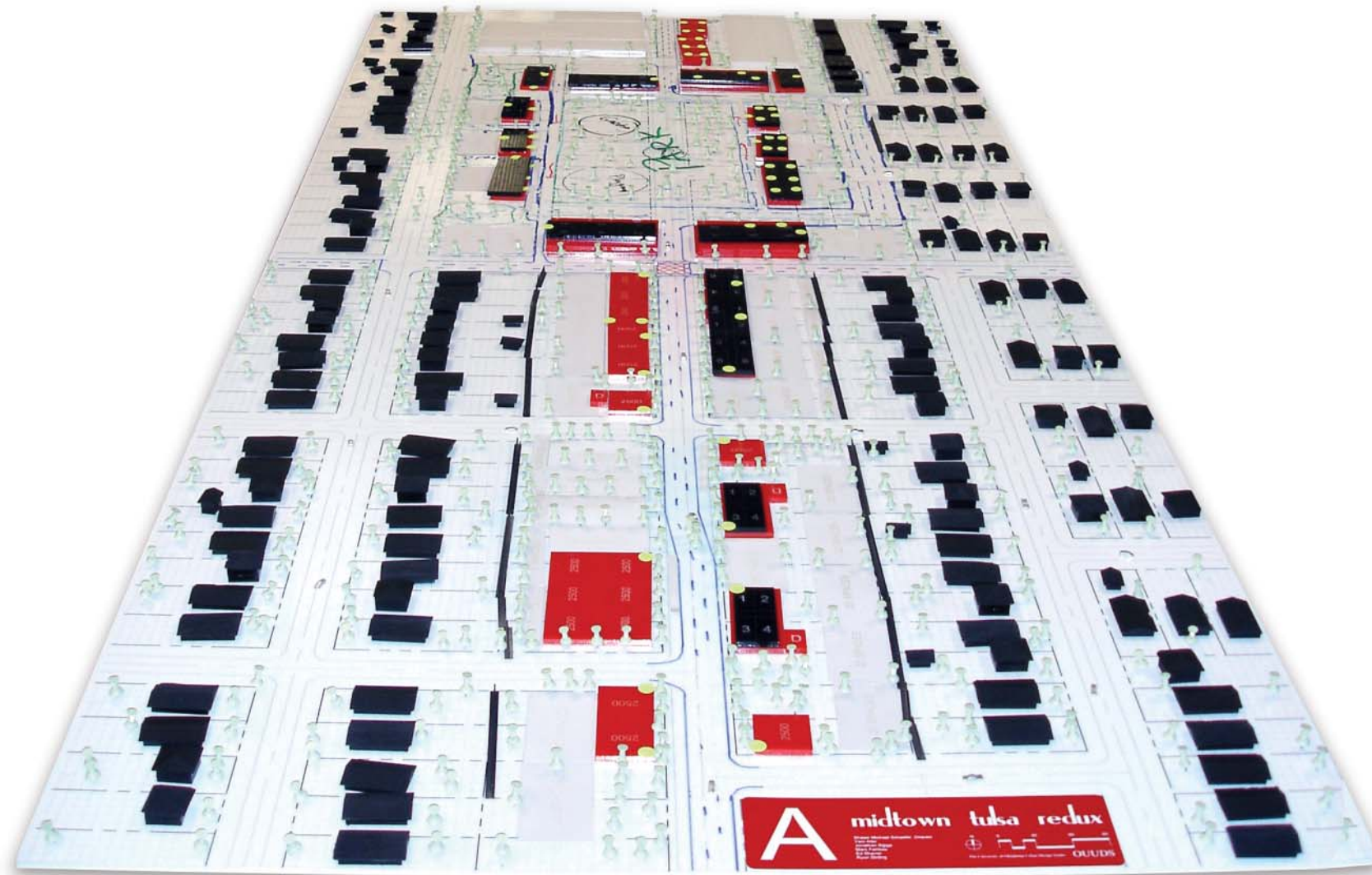

Group A agreed on spending most of their time on the park assignment. The group moved a more centralized location for this green space diverting the arterial roads to the neighborhoods for traffic calming. The area would be utilized mainly for concerts, playground, landmark and it would be a destination. Building adjacent to this area would be confined to 2-3 stories mixed use. The 300' development was created with parking and landscape to serve as a buffer while creating a "village-type" development. The group felt strongly about having mixed used development protecting residences with multi-family or town homes at the rear. In regards to buffers, they felt strongly about having the developer, city and affected neighbors participate in the selection of the appropriate buffers.

Consensus Meeting

Board B

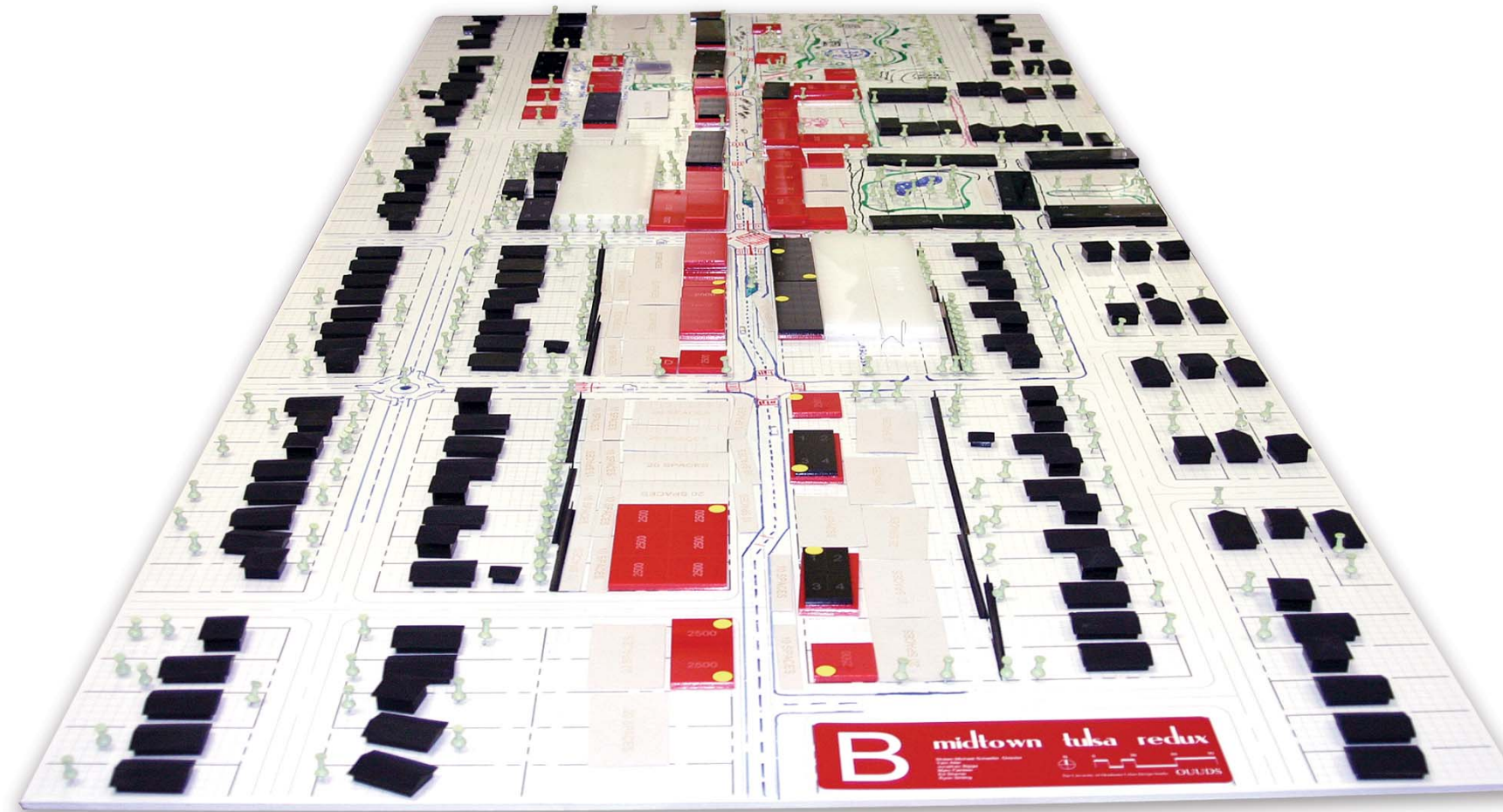

After much discussion over the merits of the game, particularly the parking requirements, new building height limit, and lack of an orientation to downtown the participants, for the most part, worked individually or in pairs around the board. The transition issue with 150' shallow lot development was dealt with a combination of screening wall and plantings. 300' deeper lot development varied from new townhomes around the perimeter with a pond and lawn between the buildings, to a mixed-use arts district that encroached further into the traditional residential area with commercial space both at the front and towards the rear of the development, and finally a higher intensity commercial intersection that had a two-bay, four-story structured parking deck behind, while buffering the neighborhood with new townhomes and a pocket park. The empty lots for green space were developed into a splash pad, playground, mini-stage outdoor theater, and jogging trail with a connection to the local trolley.

Consensus Meeting

Board C

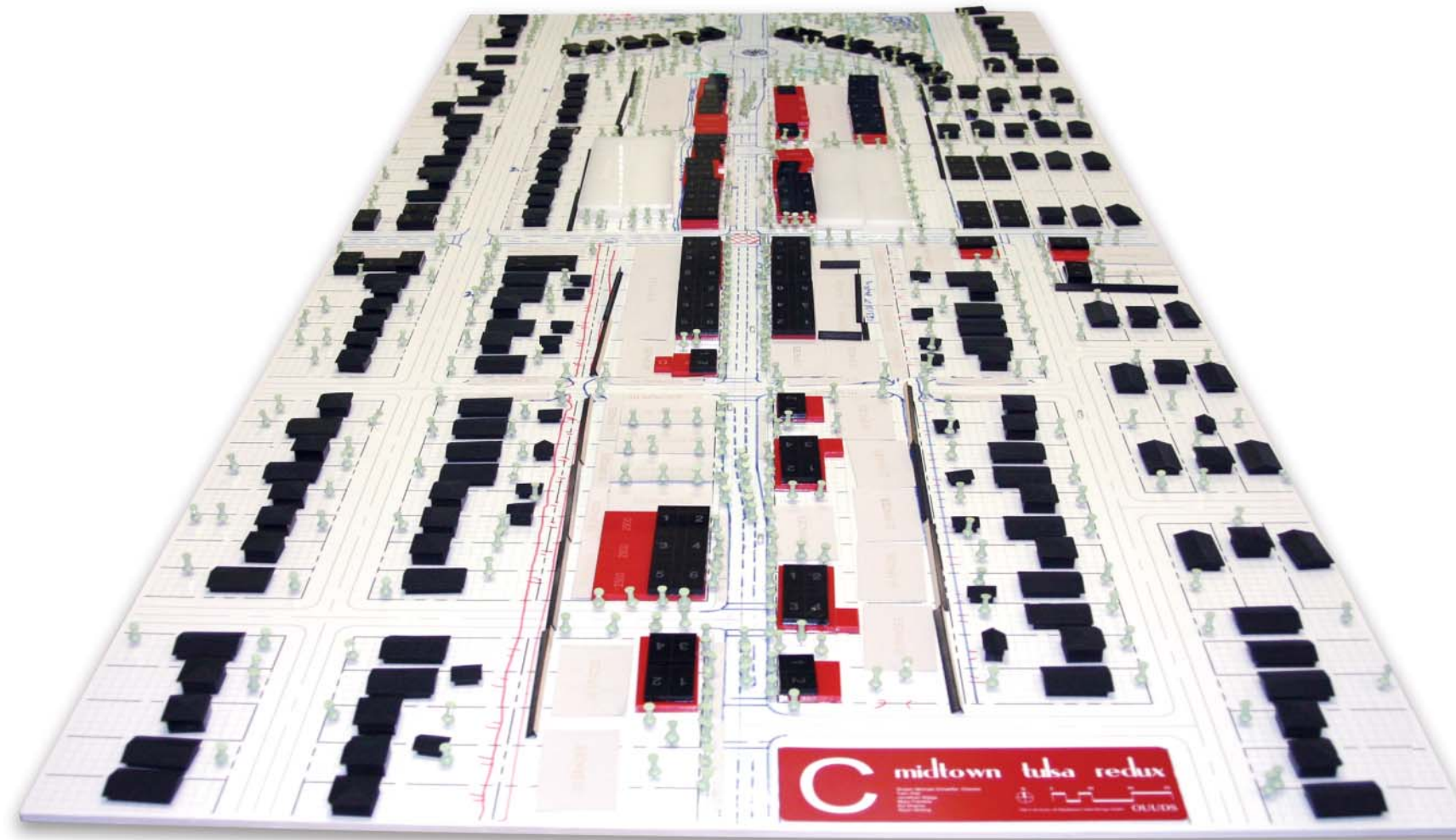

The board was developed with a large park that included a number of amenities at one end. Where the commercial development met the parkland, a roundabout was installed in the arterial, with townhomes built in a half circle pattern oriented on the roundabout. A secondary arterial came off the roundabout in one direction and a pedestrian/bike path in the other direction. Deep lot development consisted of mixed-uses along the arterial with parking in the rear and either residential properties or the secondary arterial and screening wall buffering the neighborhood.

Consensus Meeting

Gameboard Details

The photos at left depict the various “deep lot” configurations that were developed by the three teams during the consensus meeting.

- A1** A town square plan redirecting the arterial street around a large rectangular park ringed by mixed-use buildings.
- A2** Commercial development along the arterial street, multi-family rowhouses along the residential street facing the neighborhood, with parking in between.
- A3** A deep lot dedicated to a 300' long by 240' deep multi-level public parking garage serving the entire district.

- B1** Mixed-use development fronting an arterial street and single-family houses fronting the residential street, with a parking garage sandwiched between.
- B2** Similar to B1, with multi-family housing fronting the residential street along with a pocket park.
- B3** A live-work artist district, with outdoor cafes, green space, sculptures, and gallery space.

- C1** Two deep lots flanking either side of an arterial street were converted to parkland with a roundabout and multi-family housing in a half-circle pattern. One of the new legs connecting to the roundabout is a secondary arterial; the other is a pedestrian-only trail.
- C2** By creating a secondary arterial within the footprint of the deep lot, the group used this additional frontage for mixed use. Between the two mixed-use buildings is a surface parking lot.
- C3** Another example of commercial/mixed-use fronting the arterial with parking behind and then housing fronting the residential street.

Board A



A1

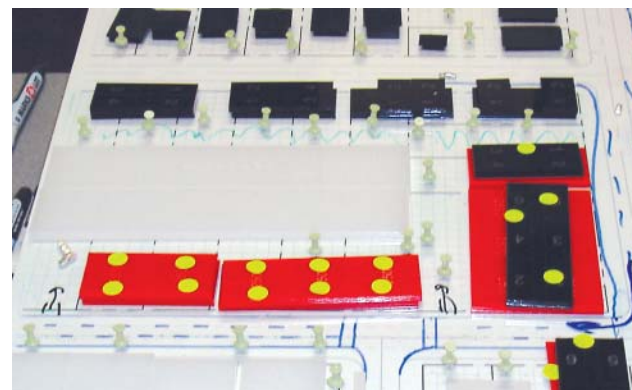

A2

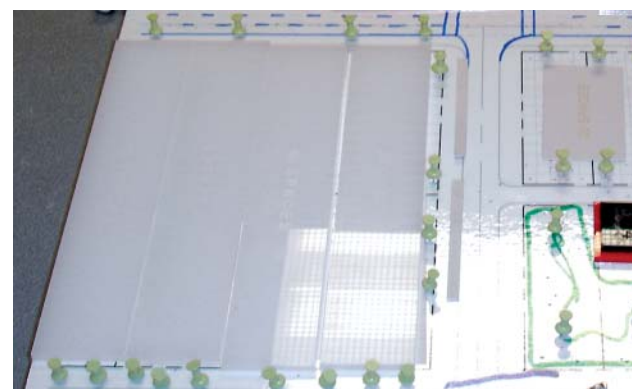

A3

Board B

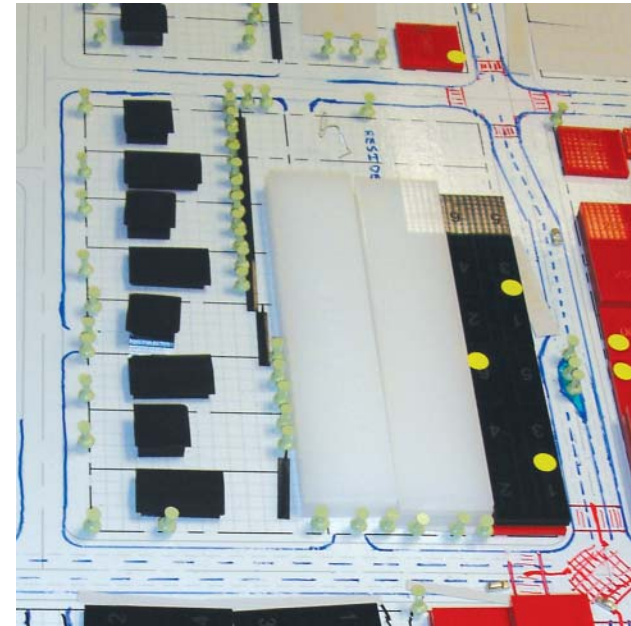

B1

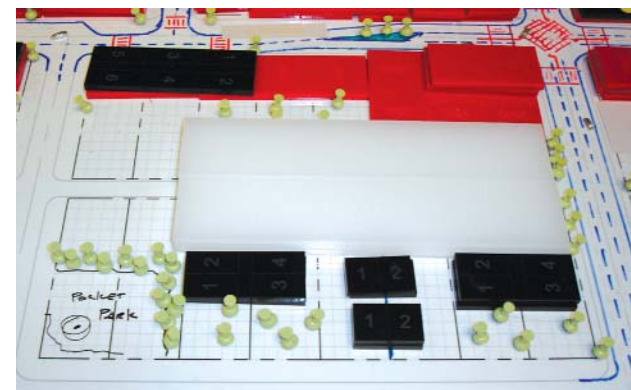

B2

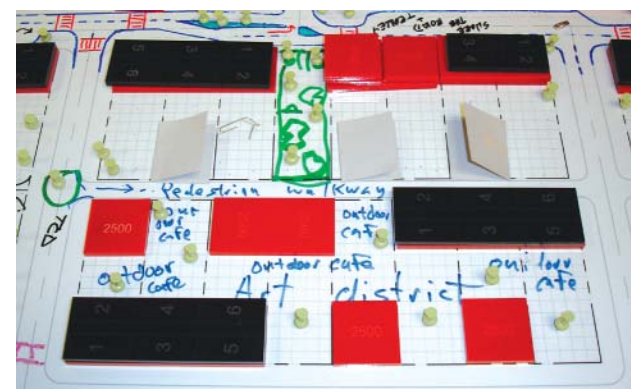

B3

Board C

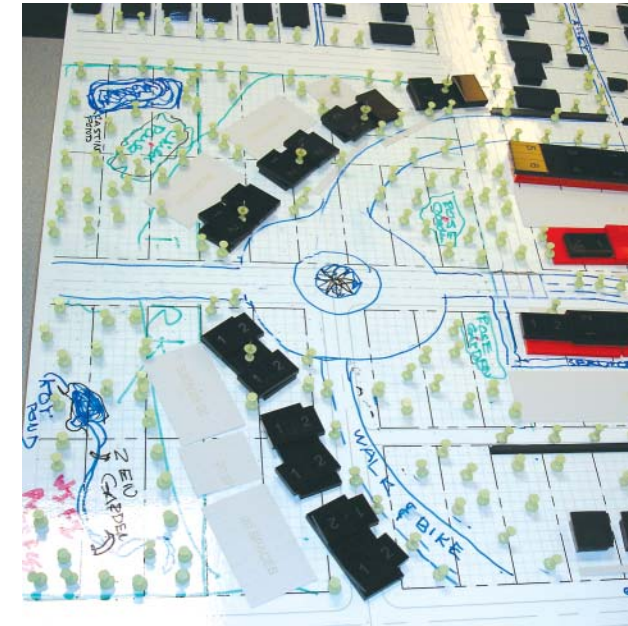

C1

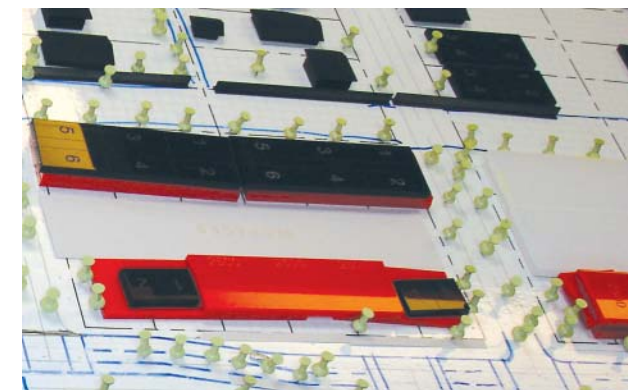

C2

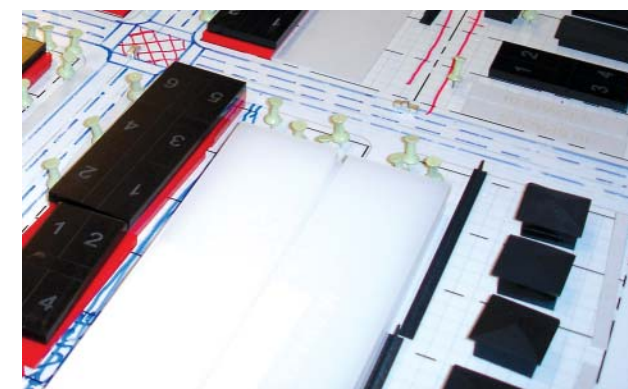

C3

Consensus Meeting

Gameboard Details (continued)

The photos at left depict the various buffer conditions between narrow lot commercial development and residential, as well as the parkland concepts developed by the three teams during the consensus meeting.

- A1** Buffers are visualized as screening walls, to be determined by residential property owners.
- A2** A large rectangular park in the middle of a town square with a fountain, gazebo, and a small playground.
- B1** Buffers were comprised of a combination of screening walls and landscape plantings.
- B2** A park with winding trails a trolley drop-off, a splash pad, a small playground, and a stage for neighborhood performances.
- C1** The group selected an alley as the buffer, with a screening wall on the commercial side of the alley, which would be used by residents to access their detached garages.
- C2** Large park spanning both sides of an arterial street, with a walk/bike trail leading into the neighborhood, rose gardens, a casting pond, a children's park, a koi pond, and Zen garden.

Board A

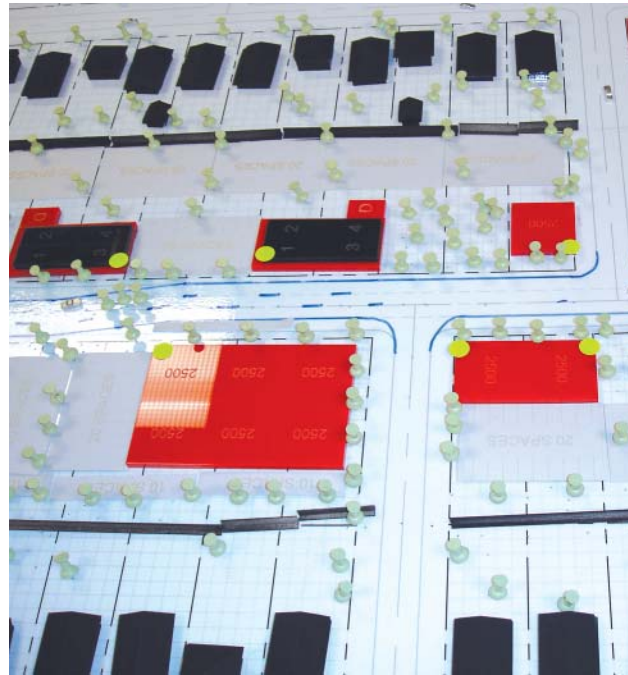

A1

Board B



B1

Board C



C1



A2



B2



C2

Consensus Meeting

Flip Chart Notes



Group A

1. Moved the park to make it more central to the entire development.
2. Segregated residential parking behind structures.
3. Development around park 2-3 stories of mixed use-adjacent parking for residential and parking garage for commercial.
4. The uses for the park would be mainly recreational: concerts, playground, landmarks, and a destination.
5. Diverted main arterials for traffic calming.
6. In the 300' development: created parking/landscape as a buffer.
7. Created mixed use development.
8. Protected residences with multi-family or town homes
9. Two stories tall max.
10. By providing buffers, one provides a restriction to the neighbors. Developer and City to ask the neighbors on an individual basis.



Group B

1. Addressed the importance of landscape as a buffer.
2. Use of a trolley for pedestrian use.
3. Motorcycle/ bike parking.
4. Alter parking requirements.
5. As part of buffer, close residential streets.
6. In deep lot development consider alleys for deliveries.
7. Also, large roundabouts.
8. 'U' shaped development with a green space.
9. New mixed use multi-family.



Group C

1. Screen on the commercial side.
2. Create a dog park, rose garden, zen garden, children's park and pond.
3. Bike and jogging trails.
4. Alleys can be good; however, there are still some questions about security and maybe the installation of speed bumps.
5. Density is the solution. The more people the less crime.
6. Creating a nice space with landscaped alley with trees and benches (extension of personal property).
7. In deep lot development: encroach into the neighborhood.
8. Housing as a buffer and development the solution.
9. Historic preservation unmentioned.
10. Consider lot orientation.
11. National interest.
12. Parking and commercial development preconceived.

— Similarities
— Conflicts

Gameboard Data

Buildings

Groups	Participants	Commercial				Residential			
		Ground Floor Commercial Modules	Upper Floor Commercial Modules	Total Commercial Units	Total Square Feet of New Commercial	Row Houses	4-plexes	6-plexes	Total Dwelling Units
Steering Panel	14	74	21	95	237,500	0	0	16	96
Residents	63								
A		54	6	60	150,000	11	9	10	107
B		73	1	74	185,000	23	9	7	101
C		65	18	83	207,500	17	6	4	65
Business Owners and Developers	17								
A		88	7	95	237,500	7	3	0	19
B		75	18	93	232,500	1	8	10	96
City Officials	28								
A		59	28	87	215,500	20	26	20	244
B		60	30	90	225,000	23	2	10	91
C		56	12	68	170,000	22	8	7	96
Mean	30	67	15	82	206,722	13	7	9	101

Parking

Groups	Required Parking	Structured		Total Structured	Surface		Total Surface	On Street Parking	Parking Total
		On Site	Off Site		On Site	Off Site			
Steering Panel		780	0	780	640	20	660	100	1540
Residents Meetings									
A	1615	540	0	540	548	296	844	42	1426
B	1020	780	0	780	420		420	112	1312
C	1258	480	0	480	980	40	1020	72	1572
Business Owners and Developers									
A	1615	300	0	300	1200	60	1260	0	1560
B	1518	1620	all shared	1620	40	0	40	70	1730
City Officials									
A	1465	1920	0	1920	120	0	120	146	2186
B	1530	960	0	960	300	0	300	360	1620
C	1156	480	0	480	600	0	600	400	1480
Mean	1,397	630	0	873	538	59	584	162	1602

Street options

Groups	Set Backs			Streets	
	Building - Front Set Back	Building - Rear Set Back	Total Houses Removed	Street Options (Lanes 2,3,4, or 5)	Street Width
Steering Panel	0	0	8		2 & 4 24' & 48'
Residents					
A	0	10	0	closed 3 streets w/trees as buffer, 4 +	Median with trees 12' typical
B	10	20	16		circular green space buffer, 2 & 4 24' & 48'
C	0 to 10	0	12		4 standard
Business Owners and Developers					
A	0	0	0	4 +	Median and trees 12' typical
B	0 except for 1, 10' setback	0	13	residential on top garages, narrow arterials to 2 lanes	As drawn
City Officials					
A	20	0	41		4 lane standard
B	60' in one block, 0' elsewhere	50	0	2 lanes + median and angled parking on each side	12' typical
C	0	60	4	2 lanes on long arterial, 4 on short arterial	typical
Mean	5	12	10		4 0

Landscaping and comments

Groups	Linear Feet - Screening Wall	Total Trees	Total Crosswalks	Comments
Residents Meetings				
A	4900	685	6	Round about w/fountain, Medians w/trees, 2 neighborhood parks, all alley ways removed, closed 3 streets
B	2500	322	15	Pedestrian bridge, circular drive way along new development of around 20,800 Sq.ft., Boulevard
C	3000	328	0	Most entrances on front, parking in rear, only one large business, all others small modules
Business Owners and Developers				
A	4000	240	0	Use fences and landscaping as buffer, create alley ways, large sidewalks, boulevards
B	0	59	19	Some green spaces between street fronting commercial, parking garage to rear
City Officials				
A	800	380	12	Bike trail, circular park, street lighting
B		135	0	
C	3600	439	46	10 single family homes added
Mean	2443	294	11	

Public meetings were conducted with residents on Jan 28, business owners and developers on Feb.4, city officials on Feb.11th and the integrated meetings on Feb.25 and Mar.4. The above data measures how various groups modeled commercial midtown development in historic neighborhoods.



Midtown Tulsa Redux

Gameboard Data

Buildings

Groups	Participants	Commercial				Residential			
		Ground Floor Commercial Modules	Upper Floor Commercial Modules	Commercial Modules	Total Square Feet of New Commercial	Row Houses	4-plexes	6-plexes	Total Dwelling Units
Consensus meetings-	32					units	units	units	
A		75	17	92	230,000	4	11	8	96
B		78	29	107	267,500	11	10	12	133
C		58	22	80	200,000	36	19	9	166
Mean		70	22	93	232,500	17	13	10	131

Parking

Groups	Required Parking	Parking						
		Structured - On site	Structured - Off Site	Total Structured	Surface - On Site	Total Surface	On Street Parking	Parking Total
Consensus meetings								
A	1564	120	240	360	660	660	200	1220
B	1819	396	564	960	550	550	100	1610
C	1360	840	0	840	780	780	230	1850
Mean	1581	452	268	720	663	663	177	1560

Landscaping and Remarks

Groups	Linear Feet - Screening Wall	Total Trees	Total Crosswalks	Comments
Consensus meetings				
A	2500	573	4	Park diverting arterial for traffic calming
B	1750	391	18	
C	1250	524	0	Bike path around the arterial, arterial added
Mean	1833	496	7	

Meeting Summaries

Neighborhood Workshop

Generally, the participants at the neighborhood workshop focused on walkable neighborhoods that reflected the historical character of the area. Comments included requests for wider sidewalks, a pedestrian bridge, parallel parking to slow down traffic, beautifying the median with fountains and landscaping and burying power lines. Most participants were open to some new development as long as it was smaller in scale and two-stories or less. Some mixed-use retail/residential was discussed as being possible in transitional areas as was multi-family housing. “Big Box” commercial was opposed by the majority of the participants. If possible, future redevelopment should adapt existing structures. Screening and parking also were important topics. The former ranged from concrete barrier walls to creating a new urban forest, while the latter brought comments regarding the viability of underground, structured parking which led to questions regarding who should pay for it. Suggestions included the developer as well as the city. A number of the attendees stressed that either the current zoning codes needed to be more strictly enforced or start all over with some sort of “umbrella special district to preserve the character of the neighborhoods.”



Developers/Business Owners

As the developers and business owners used the gameboards to depict an idealized version of midtown Tulsa, a cohesive theme emerged. Similar to the neighborhood groups from the week before, an emphasis was placed on creating a pedestrian friendly destination area that could offer that often elusive “sense of place.” To enable this to happen arterial streets were narrowed and beautified, shared parking structures were built for the district behind the buildings to allow for necessary parking and act as a buffer for the neighborhood, raised crowned walkways were implied, as were sidewalks with no curbs. On-street parking was still available but with limited time usage. One of the groups suggested a merchant owned trolley be available to shuttle people from the structured parking to the various businesses. Mixed use properties would increase the residential density of the area and allow for the necessary critical mass, essential for community development and proprietors alike. Regarding potential conflict with neighborhood associations, an individual who both lives and owns a business in the area requested that neighborhood associations be “part of the discussions, not perceived as an obstacle to development.”



City Officials/Planners

The workshop with public officials progressed much like the previous two community meetings with residents and business owners/developers – an introduction, area research summary, game playing session followed by discussion. Once divided into three groups we again saw some common themes constructed on the gameboards. Structured parking was put behind the new buildings. The footprints themselves were smaller in scale with residential units above the commercial and built to the front of the property line. Slowing down arterial traffic by narrowing lanes from 4 to 3 with a center turn lane and offering on-street parking away from the intersections, as well as intensive use of landscaping created a more pedestrian friendly environment. Thought and consideration was given regarding the impact development is and will be having, on the surrounding neighborhoods. With that stated, one group theorized that in removing some of the older homes you could create enough area to build a denser arterial that could support the additional commercial activity and allow for the necessary parking structures. Creating a destination center that benefits the cities tax base and potentially raises property values.



Consensus Meeting

The fourth community meeting brought together many of the same individuals that attended the earlier meetings held for neighborhood residents, business owners/developers, and public officials. The gameplay was altered to consider different conditions that had not been clearly established during the other sessions. These conditions included a focus on various forms of buffers between commercial development and existing residential, developing some deeper 300 foot lots, and specifying usage of green space that kept appearing on earlier models. Once divided into three groups we again witnessed some creative solutions that are described in detail on the multiple board sheets. The discussion session led to some disagreement concerning the parameters of the game and the study itself. For some, the abstract nature of the gaming model proved to be an impediment that was not easily overcome. Specific questions were raised about parking requirements, minimum commercial development, and the role of historic preservation zoning in the study area. While consensus was not fully reached within the group assembled, this data will be included with earlier research for later conclusions and possible recommendations.

Meeting Findings

1. Minimal setbacks/build-to lines

During the game-playing portion of each of the community workshops, a predominate number of the new structures along the arterials were placed with a setback between zero and ten feet, creating a build-to line that shapes an urban streetscape.

2. Parking behind buildings

Because the buildings were built towards the front property line, parking was placed primarily to the rear of the buildings, which necessitated conversations regarding buffer treatments between parking and the neighborhoods. Some parking lots were placed to the side of the buildings; practically no parking was placed in front of buildings unless it was on-street parking.

3. Develop intersections at higher intensity

The gameboard consisted of one major arterial intersection. Most of the tables used this opportunity to create a higher intensity node, building up each of the corners and then scaled back development the further away from that junction.

4. Walkability

The term walkability came up at each table and during the open discussions at all of the community workshops. Those discussions, and the developments built while gaming, suggest that a combination of traffic calming, smaller human-scale buildings with a variety of uses, and pedestrian amenities including wider sidewalks, more crosswalks, and possibly trolley service were desirable and appropriate for Midtown.

5. Bury Utilities

Second only to walkability, the notion of utilities being buried brought applause more than once. Cleaning up the visual appearance of the streetscape was important to the participants.

6. Mixed-Use Developments

With regularity, participants used commercial pieces to build one- and two-story structures and then placed residential atop to create a mixed-

use development. Another example of mixed-use had commercial buildings built to the front of the development with residential units at the rear of the property.

7. Three-story commercial maximum

Although no height limit was placed on commercial buildings during the initial three community workshops, not one table had a commercial or residential building over three stories by the end of the gaming session.

8. Four-level parking structure maximum

Structured parking was a popular solution to the parking requirement; it maximizes the number of spaces within the footprint, but often is cost prohibitive. The possibility of district parking structures built either by a developer or the city was discussed numerous times.

9. Greenspace/Parks

Five of the nine boards from the first three community meetings had some form of open green space or park land. During the consensus meeting, one of the tasks the participants were given was to define specific uses for open space. This resulted in many ideas, including an open town square concept, a splash park with jogging trail, and a semi-circular park/residential development offering a walking/biking trail.

10. Parking Strategies

The rules of the game included a parking requirement. Participants developed various parking strategies to meet that requirement, including shared parking arrangements, public parking structures, timed on-street parking, and off-site district parking.

11. Residents value preservation, both historic homes and way of life

Participants emphasized the need to preserve the overall character of Midtown Tulsa neighborhoods. The age, scale, and charm of the tree-lined streets framing classic housing styles provide a context for understanding Tulsa's rich history. That charm also drives development interest in Midtown. It is vital that some common ground be found to ensure that the essential character of the area remains.

12. Multiple “deep lot” strategies

Various “deep lot” (deeper than a single 150’ lot) configurations were developed at all four of the workshops. The most intense tended to be located at the arterial intersection and sandwiched parking between buildings with some form of buffer behind – often multi-family residential. Other ideas attempted to recreate the feeling of a town square. Deep lot tended to be around 300’ deep, which did not allow for any “Big Box” development.

13. Buffers between uses

Transitions between commercial and residential space was a topic raised many times during the workshops. Screening walls were built, trees were planted, open lawns designed – even townhomes and parking structures were built as buffers. Some groups added alleys, while some groups removed alleys. There was agreement that buffers were necessary but the particular type depended upon the development built and who the participants were.

14. Traffic calming/Street design

Many different traffic calming possibilities arose when participants were creating their gameboards. Arterial lanes were narrowed from four lanes to either two- or three-lane configurations. Once narrowed, streets could gently curve and allow space for angled or parallel parking on alternating sides of the street. Pedestrian bump-outs and crowned crosswalks would provide subtle reminders for drivers to slow down and raise visibility for pedestrians. Planted medians were also used to beautify and calm traffic.

Recommendations

“The creation of a thousand forests is in one acorn.” Ralph Waldo Emerson

The recommendations outlined on the following pages were developed to address areas of concern with Midtown Tulsa redevelopment and Tulsa’s development process as whole. The findings of the photo survey, mapping inventory, development process interviews, and community workshops all helped to inform these recommendations.

A tree is an apt metaphor for these recommendations. Just as a tree is comprised of many branches, the recommendations should be viewed collectively, as interconnected strategies that complement and support one another in achieving a broader purpose. The individual details within each recommendation, while potentially instructive, were not meant to stand alone, but rather were envisioned as part of a larger context.

You will read on the following pages that we consider neighborhood planning a key component of these recommendations. Neighborhood planning is the “trunk” of our tree. Each of the other recommendations are branches sprouting from, and nourished by, the trunk. It is critical that Tulsa residents are involved in the process of shaping the neighborhood and the city in which they live in order to ensure that our planning “tree” will be deeply rooted in the community.

Many of these recommendations make note of areas of further study. We do not envision these recommendations as being the final word on Midtown Tulsa redevelopment – it is our hope that the concepts presented on the following pages will provide the starting point from which meaningful and informed dialogue about Midtown Tulsa redevelopment can occur.

Returning to our tree metaphor, our goal with these recommendations is to plant the seeds from which larger ideas and lasting results can grow.

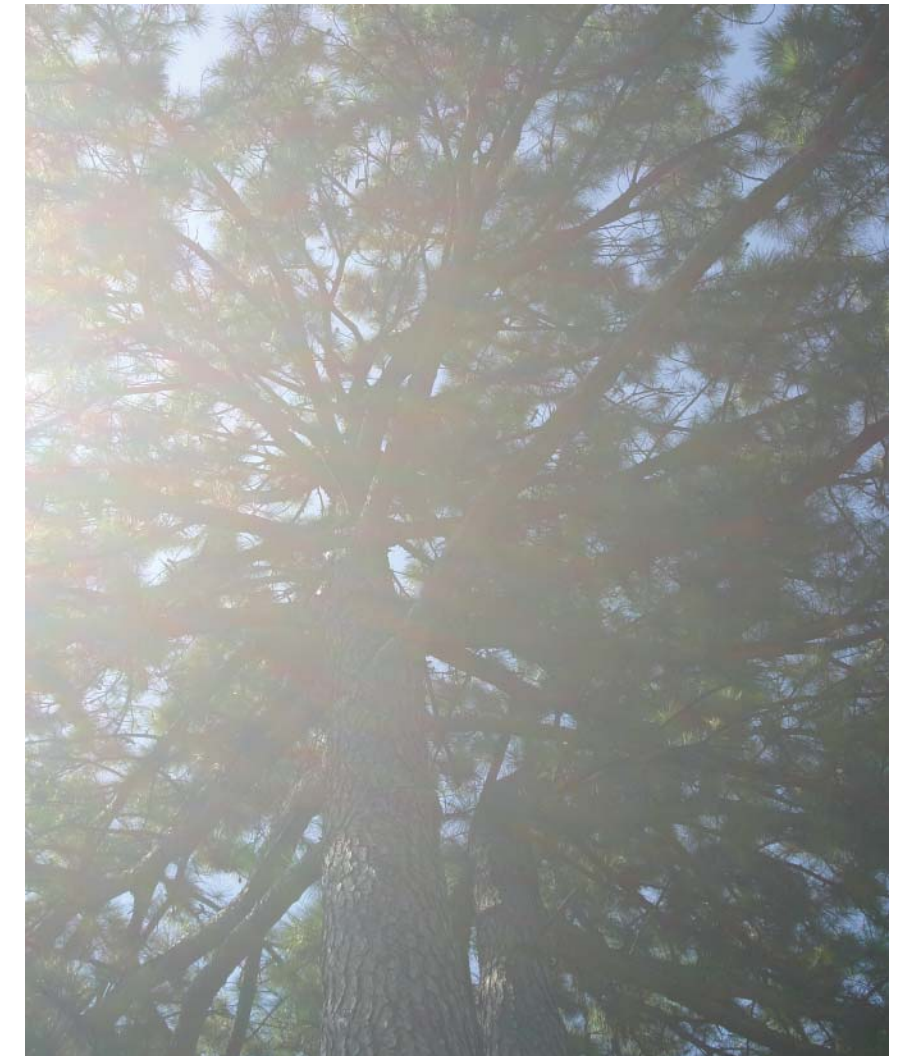

Evergreen tree, Troost Avenue, Swan Lake neighborhood

Recommendations

1. Create neighborhood plans addressing local concerns

2. Process/Communication improvements

3. Enhance predictability for developers

4. Neighborhood Advocacy

5. Revolving fund to acquire properties

6. Parking Strategies

7. Street Improvements

8. Walkability and pedestrian amenities

9. Bury Utilities

10. Zoning Changes

Recommendations

1. Create neighborhood plans addressing local concerns

Purpose To bring Midtown residents, business owners and developers, and city officials together in a proactive manner to establish plans for Midtown neighborhoods to be included as part of the updated comprehensive plan. It is hoped that this plan will be attractive for commercial and residential development while preserving the unique and desirable characteristics of the neighborhoods.

Details The recommendations contained in this report are intended to be the starting point for creating a series of neighborhood plans that are an integral part of an updated comprehensive plan for the city of Tulsa. The creation of localized neighborhood plans provides the cornerstone for the remaining recommendations.

The findings of this report, from both the community meetings and the research and mapping phase of the project, should provide city officials and neighborhoods with an understanding of the issues facing Midtown Tulsa, how the study participants would address those issues, and a toolkit of urban planning techniques developed from the findings. Hopefully, this will save time in the planning process and allow participants to focus on specific neighborhood issues and objectives, rather than starting from scratch each time.

Not every technique outlined in this report is applicable to every neighborhood. Some neighborhoods may be emerging, some may be declining, and some are more suited to being commercially-intense districts than others. The project team recognizes that even in a relatively small area like Midtown Tulsa, there is not a “one-size-fits-all” solution. Therefore, flexibility has been built into these recommendations so they may be fine-tuned for each of the neighborhoods that would want to develop a neighborhood plan.

Issues

1. The City of Tulsa and INCOG must take the lead and devote resources to developing neighborhood plans.
2. Large numbers of residents need to be invited, informed and included in the planning process.
3. Constructive dialog must occur among all participants in order to create plans that serve the greatest good for the overall vitality of the city and its quality of life.
4. Enforcing the plans will require discipline in the face of political and developmental pressures.
5. Consistent application of the guidelines established in the neighborhood plans will be essential.
6. Bringing all entities together, including developers, for productive on-going planning sessions.



Neighborhood and City Officials Meeting

Recommendations

2. Process/Communication Improvements

- Purpose** To make the development process more efficient and less antagonistic while rebuilding trust between all parties – residents, business owners and developers, and city officials.
- Details** Nothing will improve the development process more than a concerted effort to spend more time proactively developing neighborhood plans (Recommendation 1) instead of fighting or refereeing individual battles. It was abundantly clear throughout the project that nobody is happy with the current development process – it is time-consuming and expensive for developers, inconvenient for residents, and draining for city officials with limited staffing resources. There is also the very real fear that the current process makes infill development in Tulsa not economically feasible for developers, driving investment to the suburbs and retail sales tax with them. Trust needs to be rebuilt between all of the parties.
1. Schedule public meetings in the evenings. It is difficult for residents to attend meetings during the workday.
 2. Provide earlier notice of zoning request changes – 45 days instead of 30 days.
 3. Create educational workshops and neighborhood development toolkits.
 4. Updated neighborhood plans should allow for less reliance on Planned Unit Developments.
 5. Encourage developers to work more closely with neighborhoods by offering possible incentives for compromises made in HP districts such as facade easements on rehabilitations but allow larger floor area ratios (FAR) or reduced parking requirements for appropriate new construction.
 6. Develop a project management approach at the city, assigning one individual for the life of the project who will track it through the approval process.
 7. Increase development notification range of nearby residents from the current 300' to 500'.
 8. Broaden the scope of ongoing educational efforts of the TMAPC, BOA, and TPC with the public at large, but in particular with residents, business owners and developers, and city officials.
- Issues**
1. Resistance to change, including those who perceive the current process as favorable to their interests.
 2. Potentially additional time commitments for volunteers who serve on boards and commissions, in order to accommodate meeting times later in the day might be an unintended disincentive to service.



Communication Improvements

Recommendations

3. Enhance predictability for developers

Purpose	To make infill development in Tulsa more attractive to developers by making the process more predictable.
Details	<p>Infill development is a complicated process with interaction necessary between many different groups. Currently, much of the commercial redevelopment that occurs in Midtown Tulsa does so under a Planned Unit Development process. In this process, developers meet with officials from the City of Tulsa and private agents including representatives from utility, telephone, and cable companies, and INCOG in a pre-development Technical Advisory Committee (TAC) review meeting. We have been informed that, in part, these meetings are negotiations to determine who is responsible for infrastructure improvements. We recommend a clearer path to redevelopment.</p> <ol style="list-style-type: none"> 1. Publish and update all development standards in one place. (preferably available online) 2. Coordinate infrastructure improvements from the capital improvement plan with zoning designations. 3. The infrastructure should match the the zoning for the development, if not, the developer should pay for improvements on their land and the city should pay on public land/easements/right-of-way. 4. Reduce the current reliance on Privately Financed Public Improvements (PFPI). 5. Assess a development fee on projects based upon some set measure (floor area ratio, lot size, etc.) in order to provide a funding source for capital improvements. This fund would need to be front loaded by the city and dedicated solely for infrastructure. 6. Development fee could be implemented city-wide with some controls in place to ensure that fees generated in Midtown are not allocated disproportionately to capital improvements on the edges of town (and vice versa). <p>Assessing a development fee would provide developers with predictability when planning their projects. This new method of funding capital improvements would especially benefit small developers, since additional unforeseen costs can halt an entire project.</p>
Issues	<ol style="list-style-type: none"> 1. Finding a development fee formula that will generate sufficient funds for city costs associated with review and capital improvements, but not place undue burden on developers who want to invest in Tulsa. 2. Developers cite issues with receiving permits in a timely manner.
Further Study	<ol style="list-style-type: none"> 1. Determine the most equitable formula for calculating and assessing a development fee. 2. Determine appropriate fee levels, balancing infrastructure improvement needs with realistic fee levels. 3. Find a way for the city to fully front load the fund, possibly incorporate a line item on the city's 3rd penny sales tax campaign during the next funding cycle.

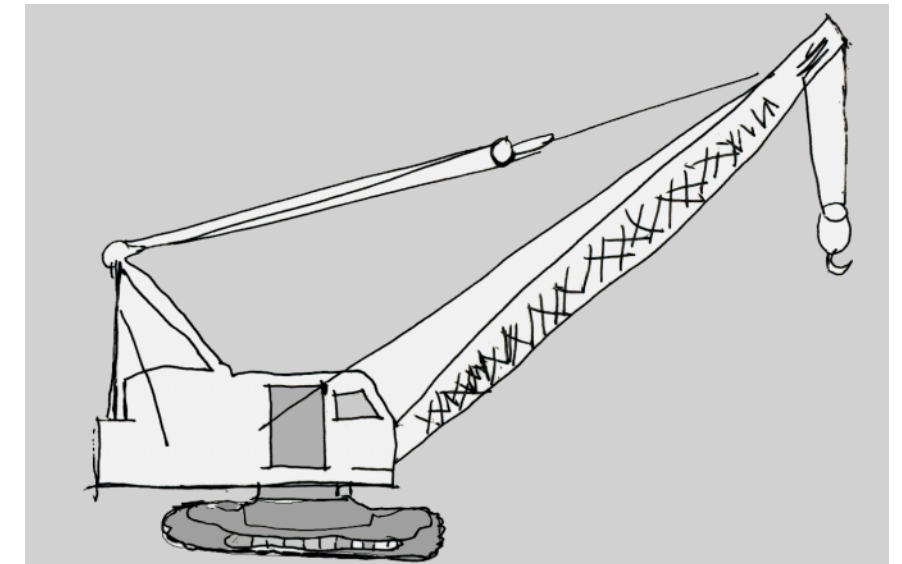

Developer's Crane

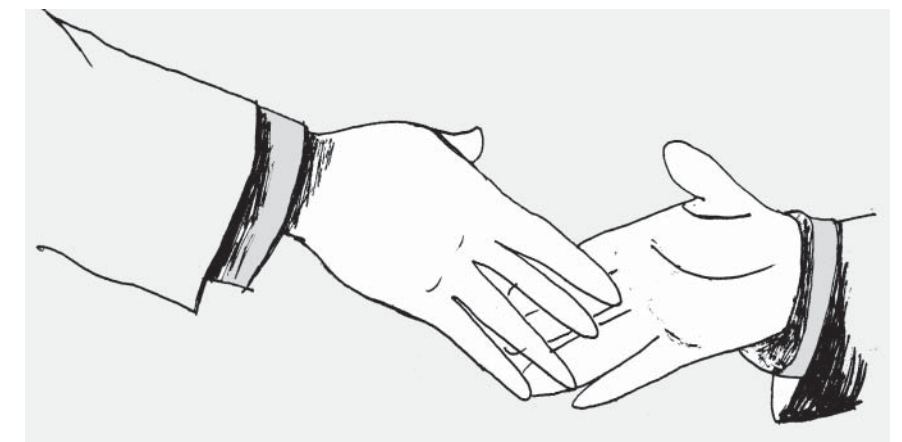

Developers and City Officials Working Together

Recommendations

4. Neighborhood Advocacy

Purpose Provide support for neighborhood associations (with the addition of local business owners) at the City of Tulsa that would enhance the effectiveness of neighborhood input through continuing education, better continuity of leadership, and advocacy.

- Details**
1. Create a city administration position that would provide assistance, training, and education to neighborhood associations and assist in articulating neighborhood interests before the city council.
 2. Should be a civil service planning position rather than a political appointment.
 3. This position would also administer the qualification criteria for neighborhood associations city-wide.
 4. Development of a neighborhood association certification program to educate neighborhood leaders and ensure adequate neighborhood representation and accountability.
 5. Create accountable, democratic, and better educated neighborhood associations that can continue to develop leaders that benefit, not only their neighborhoods but the City as a whole, which becomes especially important when public dollars are being reinvested into neighborhoods through Vision 2025 funds.

- Issues**
1. Define roles and purpose of neighborhood associations and establish certification criteria.
 2. Political obstacles include creating a new position, overcoming resistance by some current groups, lack of participation from residents, encouraging inclusiveness between neighborhoods and businesses for a broader view of what a neighborhood can mean.

- Further Study**
1. How to incorporate a neighborhood advocacy position into the city structure.
 2. Need to develop a clear and inclusive definition of neighborhood.

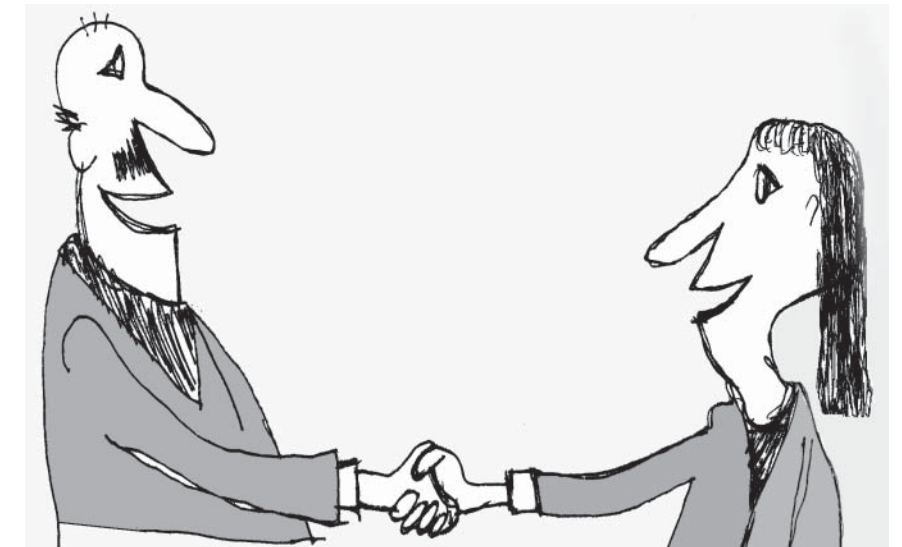

Developers and Neighbors Working Together

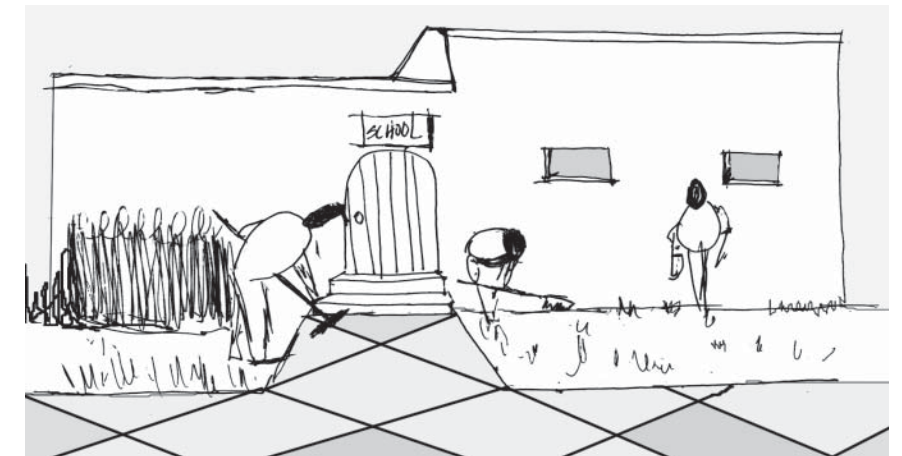

Neighborhood Improvement Through Involvement

Recommendations

5. Revolving fund to acquire properties

- Purpose** To support the neighborhood planning process by ensuring that properties considered important to the neighborhood residents, community's history, and/or quality of life are preserved.
- Details** Recognizing that Historic Preservation Overlay Zoning and/or listing on the National Register of Historic Places does not prevent building demolitions, and that many buildings worthy of preservation are not located in HP districts, the only reasonably sure way to preserve a building is to purchase it.
- Private groups of citizens, including neighborhood associations, who were willing to purchase and maintain threatened structures could establish this fund through member dues/contributions and outside donations. Funds would be used to either purchase properties outright, or purchase a preservation easement from the current owner. Depending on priorities and funding sources, there would be opportunity for foundations, non-profits, or even the city to offer matching funds.
- Issues**
1. Willingness of private groups to invest their personal resources in the fund.
 2. No guarantees the owner of the property is willing to sell the property to preservation interests.
 3. Once a building has been purchased, it must be maintained, requiring additional investment.
 4. Even a building that has been purchased could be demolished in the future if a capital improvement project would require the property, which could be legally acquired through eminent domain.
 5. Associated overhead with managing the fund.

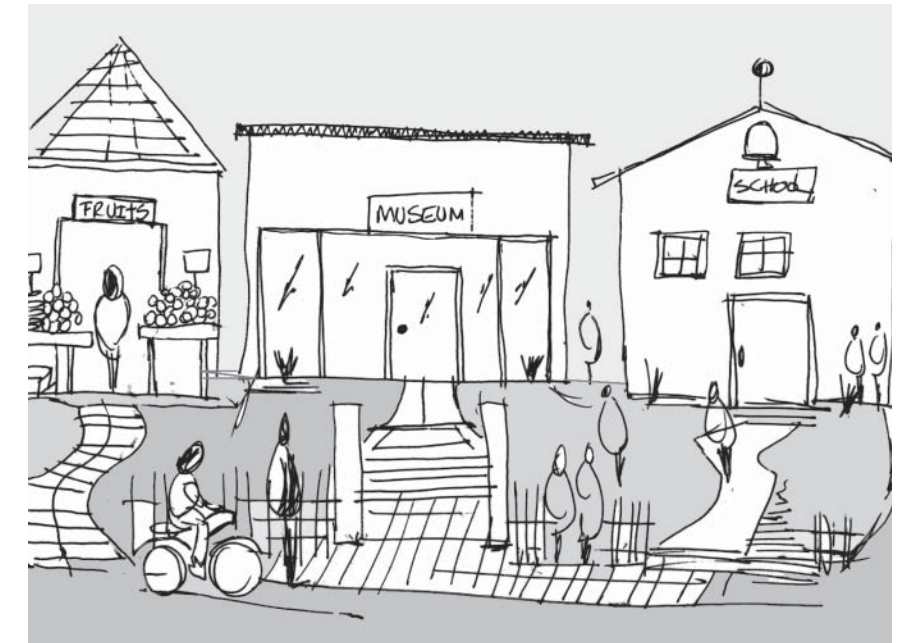

Community Involvement

Recommendations

6. Parking Strategies

Purpose	To suggest a list of strategies that could potentially be incorporated into the neighborhood plan that would provide adequate parking for commercial developments in Midtown Tulsa while maintaining a pedestrian-friendly environment.
Details	<ol style="list-style-type: none"> 1. Encourage sharing parking, either through private agreements or easements. If agreed by property owners, parking counts should be a district count, not property by property. 2. Encouraging the employees of businesses in the district to use centralized shared parking would free up on-site parking for customers. 3. Invest funds in shared parking, either surface lots or structured parking, in strategic locations throughout intense commercial districts where parking is at a premium. 4. On-street parking should be encouraged and count toward parking requirements for the district. 5. Provide a mix of short-term and long-term parking in commercial districts. Some commercial uses require short-term parking (dry cleaners, shoe repair shops, etc.) 6. Provide angled on-street parking instead of parallel parking to maximize the number of cars parked per block. Study participants suggested that angled parking is more desirable because it is easier to pull in and out of spaces than parallel parking. 7. Mixed-use developments should designate specific parking areas for residents and clearly separate those spaces from public parking. For example, a fenced-off portion of a parking lot with a pass-code gate. 8. Design of parking lots should never block vehicular movement from one development to the next. 9. Consider establishing a parking maximum in addition to a parking minimum.(see URL below) 10. Encourage alternative transportation such as bikes, trolleys, and buses which can reduce parking needs. Provide publicly-funded bike racks and/or amend the zoning code to allow a property owner to count bike rack slots toward their parking requirement with a reasonable maximum. 11. Reduce the on-site requirement with a tiered approach in proposed Urban Village (UV) zoning.
Issues	<ol style="list-style-type: none"> 1. Negotiations between property owners to establish shared parking arrangements. 2. Identifying funding for publicly-financed parking lots. 3. Liability insurance for shared lots would need to be acquired.
Further Study	<ol style="list-style-type: none"> 1. Locations for public parking structures in appropriate districts. 2. Defining tiered parking requirements. 3. Economic impact of on-site parking requirements (see http://www.planetizen.com/node/19246).



On-Street Parking

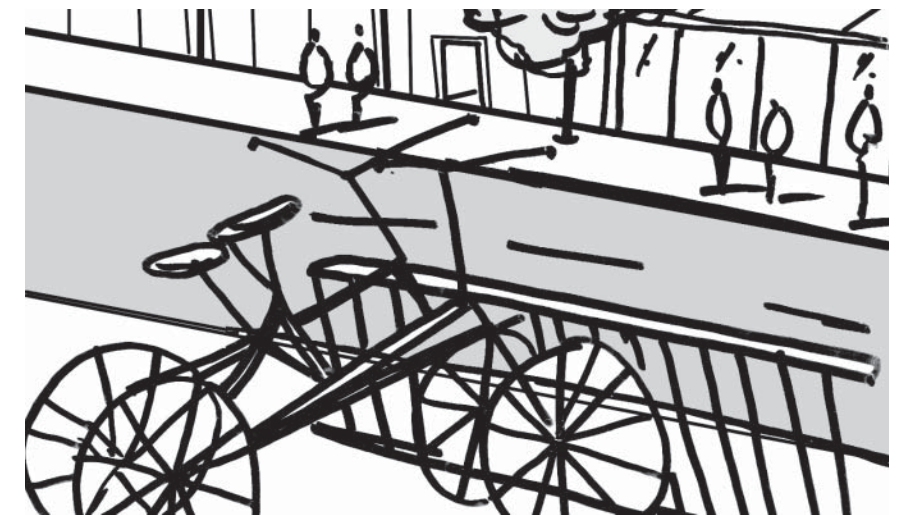

Bicycle Racks

Recommendations

7. Street Improvements

- Purpose** Create Midtown Tulsa streets that are efficient, safe, visually appealing, and of a scale that matches the districts they serve, whether vehicle-oriented or pedestrian-oriented.
- Details** There exists a variety of patterns for arterial streets in Midtown. Some arterials should be designated as higher traffic paths and others should be designated as lower-speed streets when travelling through pedestrian-friendly districts. There are a number of ways to design streets to support these objectives.
- Traffic calming measures should be employed to slow traffic, encourage a pedestrian-friendly environment and create stronger visibility for businesses along arterial streets.
1. Reduce number of lanes from 4 to 3 where traffic counts (18,000-24,000 vehicles per day) suggest minimal impact in order to calm traffic. In many cases, this would address safety issues by providing wider driving lanes on streets with narrow right-of-ways.
 2. Where pedestrian districts are to be encouraged, reduce number of lanes from 4 to 2, possibly with a center median and occasional turn lanes where needed. Crossing two lanes of traffic on foot is safer than crossing 4 lanes of traffic.
 3. When reducing the number of lanes, making an arterial street curve and wind through a district would allow on-street parking on alternating sides of the street and provide additional traffic calming.
 4. Some midtown arterials should be strategically retained as 4-lane (or even 5-lane) arterials to allow for efficient traffic flow within the city grid system. In other words, a more comprehensive traffic strategy should be developed specifically for Midtown arterials, providing both major paths conducive to larger vehicle capacity and minor paths conducive to pedestrian activity.
 5. Do not allow arterial streets to have a “flexible” number of lanes during the day. For example, do not allow parallel parking in the inside lane of a four-lane street during certain times of the day (a “two-lane” street), but allow through traffic in the inside lane during rush hour (a “four-lane” street). That flexible system creates a dangerous situation where cars must swerve to avoid parallel-parked cars in their lane of traffic. Designate a street’s number of lanes and stick to it so drivers know what to expect.
 6. Street design must be considered with all other improvements, it is an important component of urban planning in Midtown Tulsa. Otherwise, any pedestrian, zoning, and parking improvements will be less effective or negated.
 7. Coordinated street design led by urban designers, landscape architects, and civil engineers incorporating traffic engineering, utilities, sidewalks, and architecture.

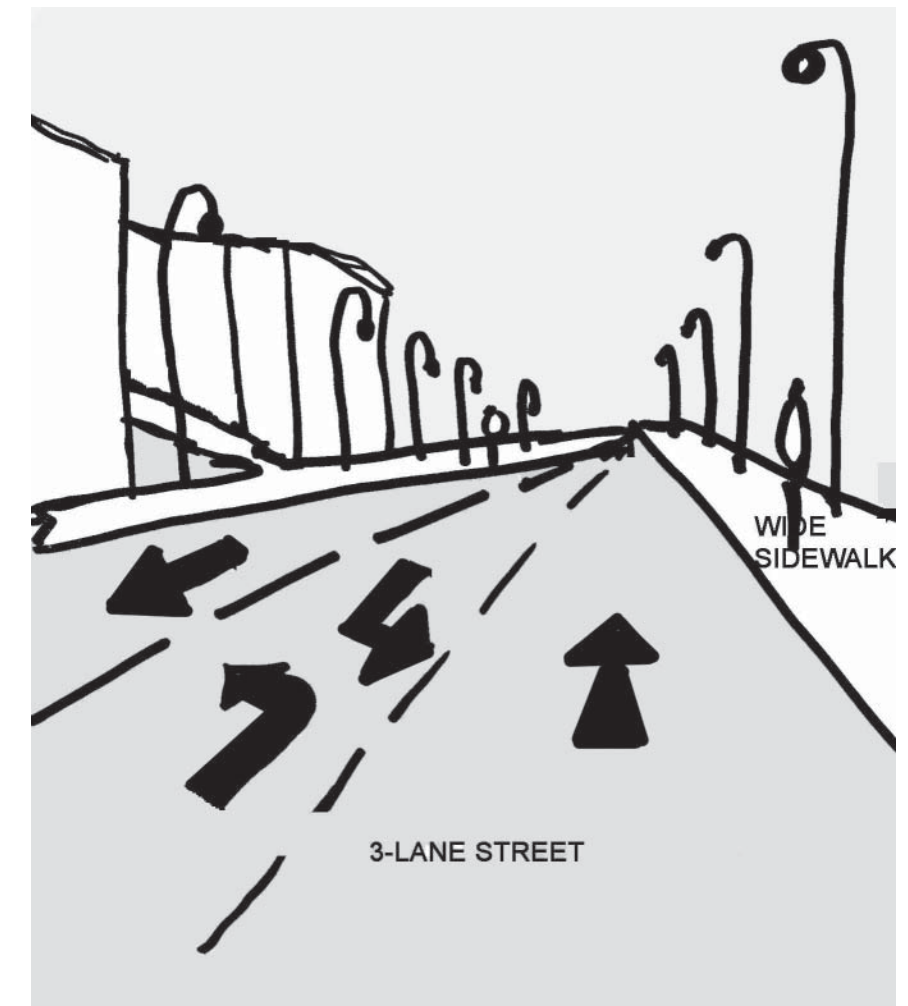

Three-Lane Street

Recommendations

7. Street Improvements (continued)

Details (continued)

8. Reduce the number of curb cuts to provide a safer environment for pedestrians by reducing the number of potential vehicle/pedestrian conflicts along the length of a sidewalk. This concept dovetails nicely with a development pattern of buildings right up to the sidewalk with parking in the rear – curb cuts can occur toward the back of the lot, away from major pedestrian paths.
9. Do not close residential streets. Although many participants of the study expressed a desire to close streets in order to keep arterial traffic off residential blocks, this will exacerbate the problem by intensifying the traffic on the other residential streets in the neighborhood. Broader dispersment of traffic is a better approach.
10. Restrict delivery trucks on residential streets in order to limit noise, prevent the congestion created by large vehicles on narrow streets, and provide a safe environment within the adjoining neighborhood.
11. Encourage a shared road concept by honoring the rights of bicylists in a multi-modal traffic structure.

Issues

1. Identifying funding for street improvements and giving priority to older areas of the city instead of expanding new infrastructure.
2. Street construction may be disruptive to businesses.

Further Study

1. Engineering Study impact of proposed street improvements, especially during peak hours.
2. Examine suggestion of closing streets to determine validity of safety claims in light of increased neighborhood traffic on newly appointed feeder streets.



Section of a Street Condition

Recommendations

8. Walkability and pedestrian amenities

Purpose	Create commercial districts that are pedestrian-friendly and continue that walkability into the surrounding neighborhoods.
Details	<ol style="list-style-type: none"> 1. Create wide sidewalks – at least 8’ wide unobstructed, preferably 10’-12’ wide unobstructed, to allow for optimal pedestrian circulation (no need to walk single file or “yield” to pedestrians walking past) and comfortable buffering from vehicular traffic. 2. A sidewalk’s unobstructed width is the critical measure and should be continuous. Avoid creating an “obstacle course” with trees, planting strips, benches, signage and utility poles that can encroach into pedestrian paths and reduce the unobstructed width of a sidewalk. 3. Beautification efforts can be a problem if not carefully planned. Sidewalk trees provide shade and buffering to pedestrians, but should be strategically planted so they do not block business storefronts and signage from view. In some cases, low shrubs or planting beds may be more practical. 4. Where on-street parking is permitted, pedestrian bump-outs should be incorporated at corners, providing line of sight for pedestrians and motorists. These corner bump-outs provide ideal beautification opportunities. 5. Strong, tall curblines are excellent buffers for pedestrians. Wheelchair ramps at corners should be cut into the curb, instead of sloping the entire curb radius at the corner, which reduces the distinction of where cars should be and where pedestrians are safe. 6. Crowned crosswalks provide pedestrians a comfortable change in elevation, rather than stepping down so far from the curb, and can also calm traffic. 7. Crosswalks should be clearly marked and re-striped often. New L.E.D. light technology is available to designate crosswalks. Provide pedestrian-triggered traffic signal lights at crosswalks that stop traffic, as often as every 1,000 feet in some heavily pedestrian-oriented districts. 8. Pedestrian amenities tie in directly with street design improvements. Narrowing streets can allow for widened sidewalks and/or on-street parking with pedestrian bump-outs. 9. Encourage outdoor cafes by use of bump-outs or establishment of build-to line.
Issues	<ol style="list-style-type: none"> 1. Identifying funding for pedestrian amenities. 2. Sidewalk construction may be disruptive to businesses. 3. Unless the Development Fee concept (Recommendation 3) was implemented, the costs of pedestrian improvements could be passed on to developers via PFPI.
Further Study	<ol style="list-style-type: none"> 1. Investigate whether the city could assess an additional property tax for neighborhoods that request improvements be made quicker than currently scheduled.



Perspective of a Cluttered Sidewalk



Crosswalk Condition

Recommendations

9. Bury Utilities

- Purpose** Improve the streetscapes in midtown Tulsa by removing utility poles and burying utility lines.
- Details** Burying utility lines would reduce visual clutter along streetscapes, reduce obstructions on sidewalks for pedestrians, improve safety for vehicular traffic, and improve the reliability of utility services. Relocating utility lines underground should be coordinated to occur at the same time as street/sidewalk improvements.
- In cases where burying utility lines is impractical, an alternative strategy is to relocate the lines and poles from the arterial street right-of-way to an easement running behind properties (possibly in alleys).
- Issues**
1. Finding funding mechanisms or incentives to encourage companies to invest in relocating their lines.
 2. Need to coordinate public and private efforts with other capital projects. Need to develop long-term plans to accomplish this goal.
 3. Street lights currently using utility poles will need alternatives.
 4. Multiple entities including cable, phone, and electrical companies as well as the city will need to coordinate efforts.
 5. Realization that this effort will take a considerable amount of time to fully implement.

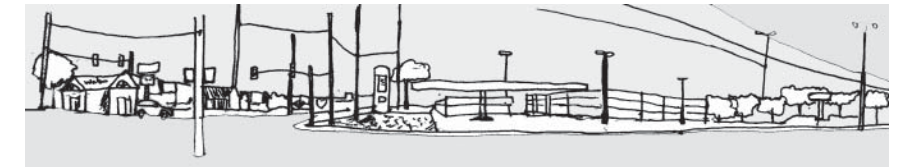

Before Burying Utility Lines

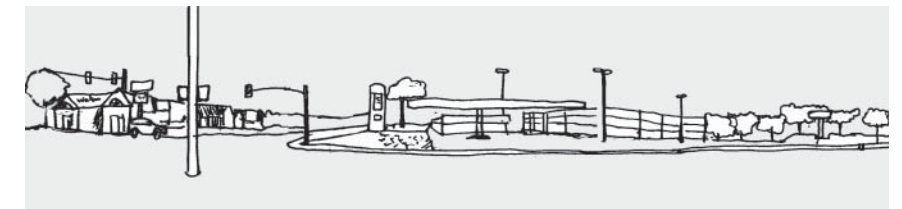

After Burying Utility Lines

Recommendations

10. Zoning Changes

Purpose

To encourage the development pattern that neighborhood residents, developers and city officials feel is most effective and appropriate for Midtown Tulsa. The current underlying zoning, which is applied city-wide and requires a suburban-style development pattern, prevents the pedestrian-friendly commercial development pattern that study participants would like to occur in Midtown Tulsa. The current zoning is too broad; it treats all areas of the city the same. This study has clearly determined that there are characteristics of Midtown Tulsa that should be preserved, encouraged, and reinforced – not eroded by incompatible infill development.

Therefore, we recommend that a new zoning type be created and added to the Tulsa zoning code that specifically shapes a development pattern appropriate for older parts of Tulsa, including Midtown. Planners would then have the option of applying zoning that would dictate either a suburban-style development pattern, or an urban, Midtown development pattern. We are calling this new type Urban Village (UV) zoning.

The cornerstone of UV zoning is to permit by right the type of urban, pedestrian-oriented developments that neighborhood residents, developers, and city officials all agreed was appropriate for Midtown Tulsa. The current underlying zoning throughout Midtown would not allow the existing buildings in many cases without seeking variances or undergoing the expensive, time-consuming, and contentious PUD process. Yet, it is the pattern created by these existing buildings that study participants want to preserve and encourage in Midtown. Instead of treating potential developments that would fit this desired pattern as an exception to the current zoning, the zoning should be changed to allow the desired development by right.

In addition to outlining a development pattern that is more consistent with, and appropriate for, Midtown Tulsa, the new zoning would specifically address the buffers between commercial development and adjacent neighborhoods. It is critical that buffering be a part of the new zoning, since the existing conditions in Midtown combined with the desire for walkable commercial districts will continue to create these transition areas of potential conflict. Outlining appropriate buffers in the zoning code would be more predictable for developers and provide more safeguards on the quality of life for residents. Site plans submitted for city permit review should include 1) all adjacent properties and 2) all properties that lie across a residential street from the proposed development, with buffering solutions designated.

It is not the intent of the study to suggest wholesale rezoning of vast portions of Tulsa without input or further study. Rather, this new proposed zoning type would simply be one more tool to be potentially implemented during the neighborhood planning process (Recommendation 1). UV zoning should be applied only where it is considered appropriate for the specific area as determined during the neighborhood planning process.



Building setback at right breaks up the continuity of the streetscape



A more continuous and pedestrian-friendly streetscape

Recommendations

10. Zoning Changes (continued)

Details The Urban Village Zoning concept as outlined on the following page is not conventional use-based zoning, nor is it form-based zoning. Rather, it could be considered as being positioned between conventional and form-based zoning. Whereas conventional zoning is concerned primarily with separating uses and form-based zoning is concerned with regulating the physical form that developments take, Urban Village zoning would combine elements of both – some use restrictions and some form considerations.

Issues

1. Likely political opposition to changes in the Zoning Code from many corners – residents, developers and city officials – who have vested interest in current zoning or fear change.
2. Expense and time required to fully develop, approve, and implement zoning changes.
3. Retraining city staff and inspectors on the new zoning type.

Please see Appendix 1 for further details on the proposed Urban Village Zoning concept.

	Form-Based	UV	Conventional
Bulk and Area	Required		Restricted
Uses	Mostly Unrestricted		Prescribed
Off-Street Parking	Restricted		Required
Middle Ground			

Conclusion

The Midtown Tulsa Redux Project succeeded in bringing together neighborhood residents, business owners and developers, and public officials to examine the dynamics of redevelopment for Midtown Tulsa. This area of town is indeed unique and worthy of preserving its inherent characteristics and charming scale. Recognizing that change is a constant, a proactive approach regarding how that transformation occurs can ensure the best possible outcome. While differences of opinion undoubtedly still exist, the common ground found during this study should serve well as a foundation to furthering understanding.

By expanding the scope defined herein and beginning the implementation of the study's recommendations through the neighborhood planning process, our goals and objectives can be fully met. We encourage this project's Steering Panel to continue meeting and sharing ideas. This dialogue not only enhances the perspectives of the parties involved but can bring illumination of the development process to the larger Tulsa community.

We have learned some lessons while conducting this study. One of the lessons learned, of course, is the importance of having active representation from all interested parties. Our study certainly could have benefited by having the two medical centers represented throughout. The fact is that within our research study area, both Hillcrest and St. John Medical Centers are major property owners, as well as developers — both were asked to take part in this study and chose not to participate.

Communication served as a cornerstone to this study — the vested parties must have open, honest interaction if progress is to be made. A lesson that hinges on this concept of better communication was our delineation between the research study area and the broader theme of Midtown. Clearly we needed to place stronger emphasis on the fact that the study area was to provide a starting point for gathering data, but that our purpose was always to apply that data to Midtown as a whole.

Our charge was to investigate commercial redevelopment along arterial streets in Midtown Tulsa. The encompassing issues include scale, massing, parking strategies, and transitions between commercial development and adjoining neighborhoods. Those elements then lead to more qualitative concepts that we heard repeatedly from study participants, such as walkability, human-scale development, buffer solutions, and visually-enhanced streetscapes.

With the advantage of hindsight, it is possible to see how Midtown Tulsa Redux meshes with last year's studio project, Tracy Park and Gunboat Park. Their master plan for two near-downtown neighborhoods provided a logical context for our study's focus on redevelopment throughout Midtown. Taking this study further, the development of a neighborhood planning toolkit to facilitate the implementation of local neighborhood plans seems like a natural progression. The recommendations contained in the final section of this report are intended to support the findings of our mapping research, photo survey, interviews and the community workshops. With this information and some further study, appropriate infill commercial redevelopment is obtainable.



Cherry Street looking east, where concepts of human-scale development, walkability, on-street parking, and visually-interesting streetscapes are apparent.

Resources

Organizations

Swan Lake Representative

<http://www.neighborhoodlink.com/tulsa/swanlake>

Cherry Street Merchants Association

<http://www.cherryst.com>

Lewiston Gardens Representative

<http://www.cityoftulsa.org/Community/Neighborhoods/NeighborhoodList.asp>

Maple Ridge Representative

<http://www.cityoftulsa.org/Community/Neighborhoods/NeighborhoodList.asp>

Yorktown Representative

<http://www.cityoftulsa.org/Community/Neighborhoods/NeighborhoodList.asp>

Tulsa City Council

<http://www.tulsacouncil.org>

City of Tulsa Urban Development Department

<http://www.cityoftulsa.org/OurCity/Departments.asp>

Tulsa Preservation Commission

<http://www.tulsapreservationcommission.org>

Tulsa Metropolitan Area Planning Commission (TMAPC)

<http://www.incog.org/TMAPC/TMAPC.htm>

Websites

City of Tulsa Ordinances

<http://www.cityoftulsa.org/General+Information/Ordinances>

Tulsa Preservation Commission

<http://www.tulsapreservationcommission.org>

Sanborn Library LLC

<http://sanborn.umi.com>

U.S. Census

<http://www.census.gov>

Tulsa Metropolitan Utility Authority

<http://www.tulsawater.com>

Tulsa Metropolitan Area Planning Commission (TMAPC)

www.incog.org/TMAPC/TMAPC.htm

Reference Sources

City of Tulsa 918.596.2100

Metro Lofts 713.661.1848

USGS Topographic Maps mcmcweb@usgs.gov

TMAPC/INCOG Zoning Maps incog@incog.org

Technical Advisory Committee 918.596.7513

Tulsa Preservation Commission, Jim Turner 918.596.2600

Tulsa Metropolitan Area Planning Commission incog@incog.org

Tulsa Metropolitan Utility Authority 918.591.4051

U.S. Census Bureau Info@census.gov

Midtown Neighborhood Coalition n/a



Midtown Tulsa Redux

Appendix 1

UV Zoning Model Guidelines

Outlined on the following pages are concepts for a new zoning type that could be considered for Midtown Tulsa, which we are calling Urban Village Zoning. These are simply concepts intended to provide a starting point and general direction for future groups studying the issue of appropriate Midtown zoning. The ideas presented are meant to reintroduce a development pattern to Midtown Tulsa that would be compatible with the commercial development that has historically existed in this part of Tulsa. Specific concepts of the zoning are intended to mitigate points of conflict and ease transitions between commercial development and adjacent residential neighborhoods through buffering solutions. The Urban Village Zoning concepts presented here are far from a finished product – further study is required.

By proposing this new zoning type, we are in no way suggesting that vast areas of Midtown Tulsa be rezoned indiscriminately. Urban Village Zoning would simply be one of several potential tools used as a part of a larger strategy for Midtown development. As previously recommended, this development strategy should emerge from a community planning process. In this way, Urban Village Zoning would be applied only where it was considered appropriate and enjoys buy-in from parties of interest.

The table below provides an overview of the proposed Urban Village (UV) Zoning types and the criteria for selecting appropriate sites.

Type	Purpose	Criteria
Urban Village Zero (UV0)	To allow by right the conversion of single-family homes to limited office uses.	Appropriate where single-family houses front arterial streets; where live/work uses are encouraged; possible transition zoning between residential properties and higher-intensity commercial uses.
Urban Village One (UV1)	Commercial zoning along arterial streets on lots 150' deep or less.	Appropriate where small-scale commercial/mixed-uses are to be encouraged. Best applied where 150' deep lots run perpendicular to an arterial street and back up to the rear yards of adjoining residential properties.
Urban Village Two (UV2)	Commercial zoning along arterial streets on lots deeper than 150'.	Best applied where assembled lots stretch from an arterial street to a residential street, which would typically provide a depth of 300' in Midtown Tulsa; also appropriate at arterial intersections.
Urban Village Three (UV3)	Commercial zoning along arterial streets on lots deeper than 300' in a "town square" pattern.	Best suited for one corner of arterial intersections, potentially where large parcels of land are vacant and the area in need of economic revitalization.

Purpose To allow by right the conversion and new construction of single-family homes for limited office uses. Also might be considered an expanded version of home occupations allowed by right in residential properties in the current zoning code. The allowed uses would be limited in order to prevent tear-downs that would be replaced by more intense uses that are allowed by current light office zoning.

Criteria Appropriate where single-family houses front arterial streets, or where live/work uses are encouraged. Could be used as buffer zoning for a few lots into a neighborhood to transition between residential properties and commercial uses along an arterial street. Also appropriate where UV1 and UV2 zoning are side by side along the same linear district to alleviate the condition of residential frontages facing the side of deeper commercial developments.

Details Uses would be restricted, similar to currently allowed home occupations permitted by right in Section 402.B.6.a of the Tulsa Zoning Code, in order to minimize the impact on the adjoining neighborhood. These occupations include artists, authors and composers, catering/food service, computer programming, home cooking and preserving, home crafts, ironing, sewing, telephone answering and/or solicitation, and tutorial services. This list might be expanded to include uses such as offices for lawyers, doctors, certified public accountants, and design professionals.

Unlike the current zoning of allowed commercial uses in residential properties, small signage will be allowed. Home occupation restrictions set forth in Section 402.B.6.a.4 (mechanical equipment), 402.B.6.a.5 (exterior alterations), 402.B.6.a.6 (outside storage), and 402.B.6.a.8 (vehicles) would be requirements of UV0 zoning.

Parking would be restricted to help ensure low impact uses. On-site parking shall be required at a rate of 1 space per 300 square feet of the building, with a minimum of 5 parking spaces and maximum of 12 parking spaces. The on-site parking requirement could be reduced with a district parking strategy that includes on-street parking. Parking must be behind or to the side of the building (no further forward than the front setback). Paving will be restricted in the front of the property to only allow driveway passage to parking deeper in the lot. Curb cuts shall be allowed on to arterial streets and/or residential streets. Parking that is within view from adjoining residential streets should be screened with landscaping.

New construction must have a residential scale compatible with existing residential buildings within the UV0-zoned district, including matching the predominant front setback of existing buildings (0 - 40'). Buildings will be restricted to two-stories. The goal is for new development to complement existing structures so that the district will retain its defining characteristics.

Appendix 1

UV Zoning Model Guidelines Urban Village Zero (UV0)

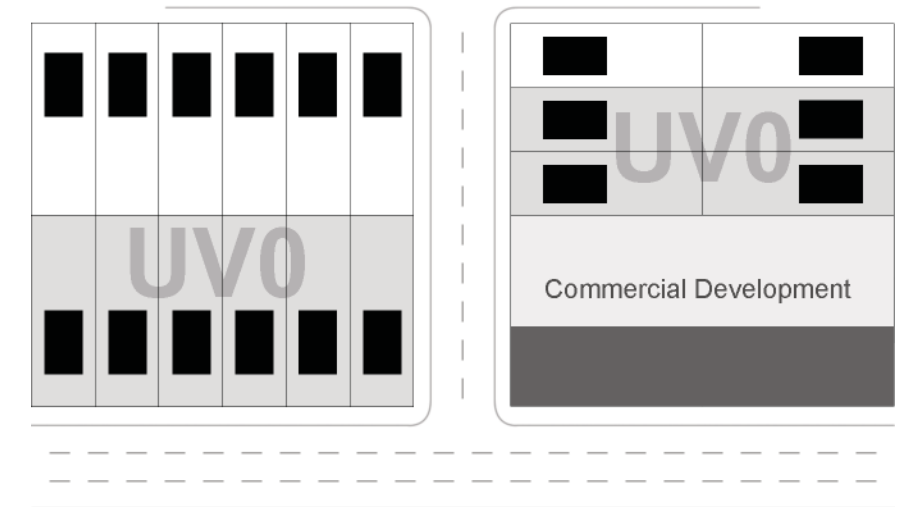

Urban Village Zero Zoning. Typical application is pictured at left. UV0 used as a buffering technique pictured at right.

Appendix 1

UV Zoning Model Guidelines Urban Village Zero (UV0)

Issues

1. Will require a collaborative effort on the part of neighborhoods and the city to determine which properties could be zoned UV0, which could potentially include properties currently zoned residential.
2. Pressure to allow more uses than allowed under UV0.

Further Study

1. Other uses may be appropriate by right for UV0 zoning but further study will be necessary to create an exhaustive list.
2. Restrictions on hours of operations may be necessary.
3. Define restrictions on signage dimensions and placement.
4. The affects of additional water run-off due to new paving surfaces for parking will need to be examined.
5. Design guidelines defining a “residential style” for new office construction will need to be defined.

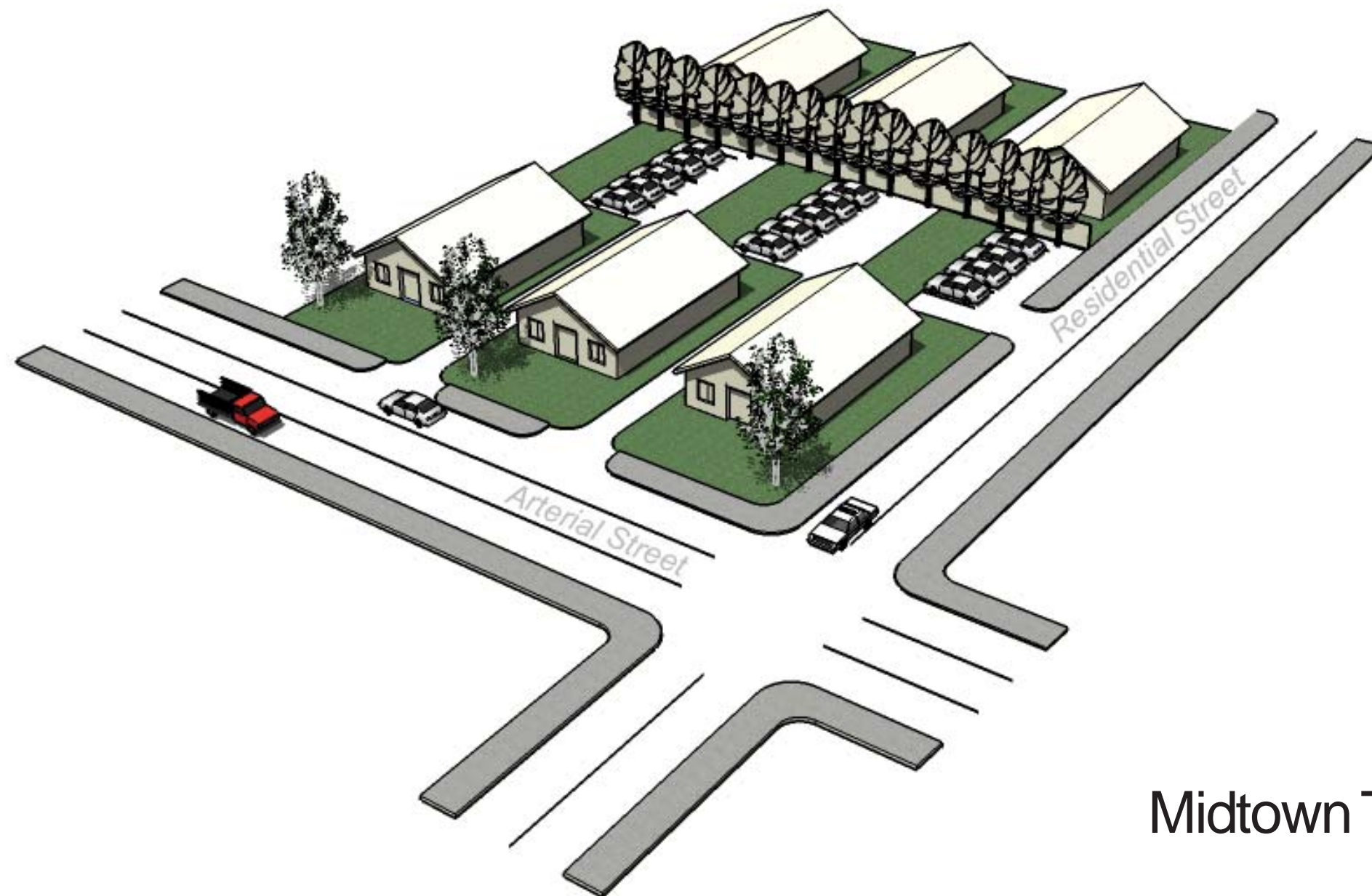

Appendix 1

UV Zoning Model Guidelines Urban Village One (UV1)

Purpose Commercial zoning along arterial streets on lots 150' deep or less. In order to create a pedestrian-friendly district, commercial buildings would be required to be built up to the sidewalk with parking located behind or to the side. Much of the existing commercial development along arterial streets in Midtown Tulsa already fits this pattern, but current zoning does not permit this type of development by right (due mostly to setback requirements). UV1 zoning would ensure that new construction would be compatible with the existing development pattern without the need for a variance.

Criteria Appropriate where small-scale commercial/mixed-uses are to be encouraged. Best applied where 150' deep lots run perpendicular to an arterial street and back up to the rear yards of adjoining residential properties. In these cases where the side of a lot fronts an arterial street UV1 zoning should be applied no deeper than three (3) lots into the neighborhood (no more than 150' deep) and the buffering options described in the Details section below should be implemented.

UV1 zoning may prove difficult to apply at arterial intersections, where a greater depth for higher-intensity development is often necessary. UV1 and UV2 zoning can be applied within the same linear district to create interest, relieve development pressure, and allow room for district-wide shared parking.

Details UV1 zoning will establish a build-to line at the front property line, which will depend on the width of the adjoining sidewalk in the public right of way. (A sidewalk of less than 6' wide, measured from curb to edge of right-of-way, would result in a build-to line that is set back 5' from the front property line.) Otherwise, the build-to line will be the front property line. Restaurants and nightclubs may apply for a variance of up to a 16' setback to allow for front patio seating for their patrons as long as their facade still comes to the newly established building line. Some lots may require view easements and a front setback for public safety on curving streets. Buildings shall be restricted to two-stories.

Parking must be located behind or to side of the building (no further forward than the front setback). The main entrance of the building must be oriented to a sidewalk that is adjacent to an arterial street. Curb cuts are allowed on to residential streets to provide access to parking in rear of building. Drive-thru windows must be restricted to the rear of the building (parking lot side).

Where commercial property abutts the rear yards of residential properties:

1. Screening walls built on the property line.
2. Consider using alleys and/or pedestrian/bike paths as a buffer. A determination needs to be made whether the alley is intended to be access to the residential properties, the commercial properties, or both. Study participants most often designated alleys as commercial access (with a screening wall on the residential side of the alley and no screening wall on the commercial side of the alley) but no true consensus was reached.

Where commercial property abutts the side yards of residential properties:

1. Provide a 10' landscaped greenbelt buffer (pictured at right). A 10' rear setback would be established with the screening wall erected on the setback line, not the property line. The screening wall should also respect the front setback of the adjoining residential properties, with landscaped corners. The maintenance of the landscaped buffer would be the responsibility of the developer, unless the property is deeded to the residential property owner.

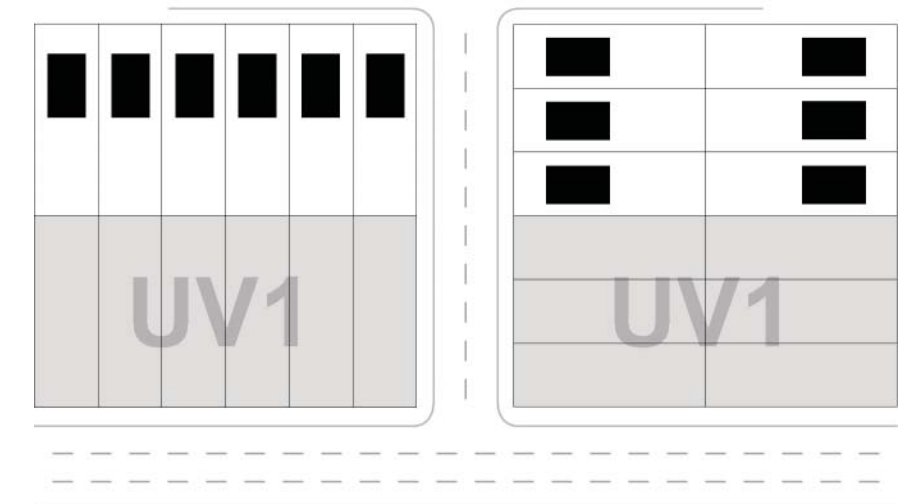

Urban Village One Zoning. The location on the left is preferable to the location on the right. Buffering is pictured below.

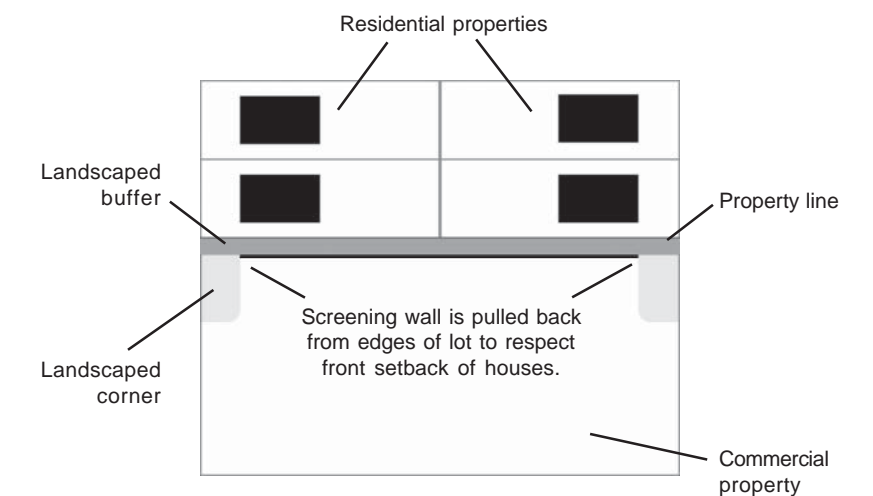

Appendix 1

UV Zoning Model Guidelines Urban Village One (UV1)

- Issues**
1. How to accommodate modern developments such as gas stations, etc. Most likely appropriate at arterial intersections away from residential.
 2. Pressure for deeper lot developments.
 3. Determining the designation of alleys where employed.
 4. Ensuring that the landscape buffer is properly maintained (may require code enforcement).

- Further Study**
1. An economic study on how much small retail can be supported within a district should be conducted to inform the decisions of which properties to zone UV1.
 2. Restrictions on FAR and uses should be analyzed.
 3. Determine what are appropriate landscaping materials to be used in the buffer.

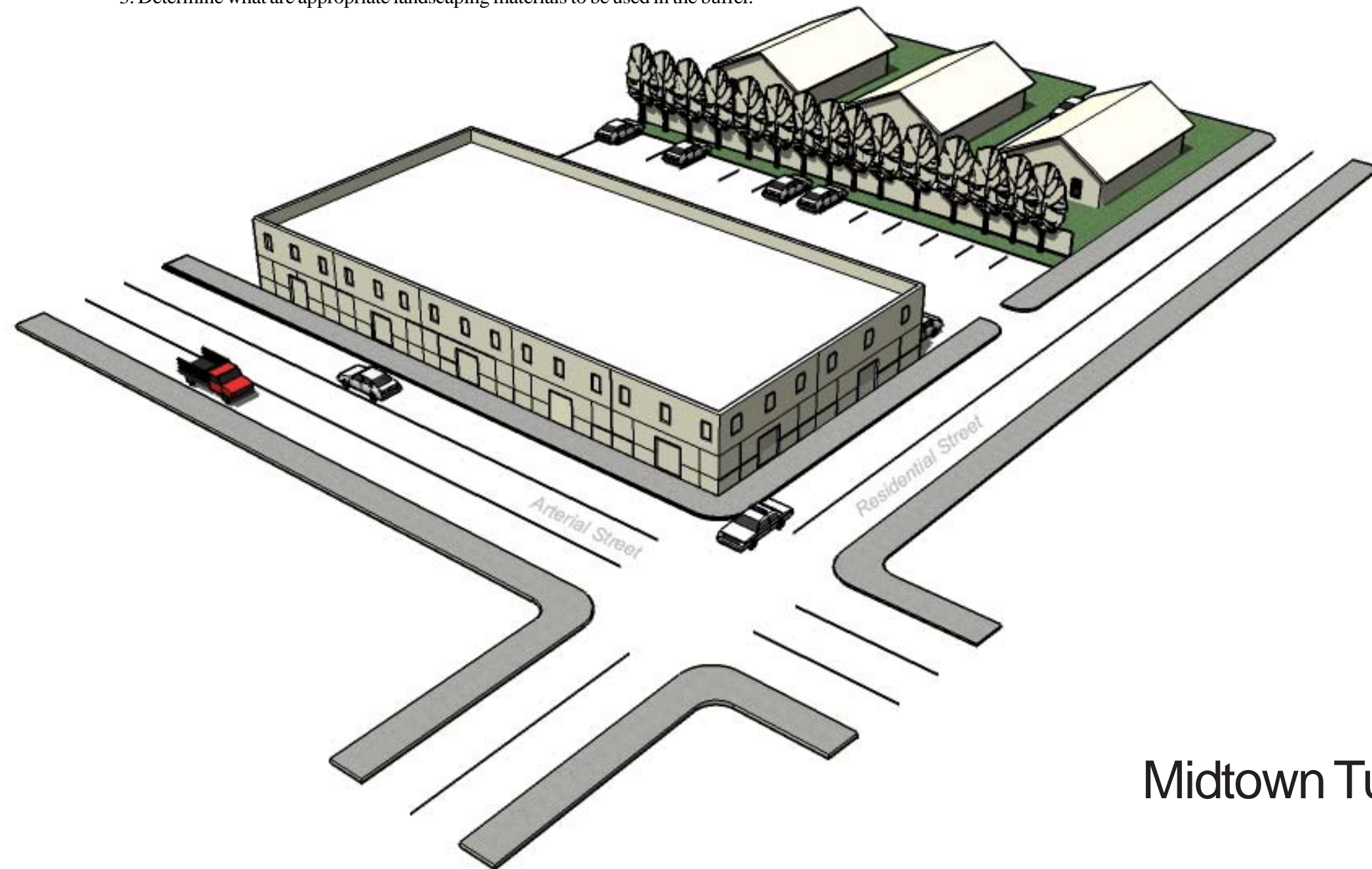

Appendix 1

UV Zoning Model Guidelines Urban Village Two (UV2)

Purpose Commercial zoning along arterial streets on lots deeper than 150'. Recognizing that some developments require a greater depth than 150', but that commercial development several hundred feet deep would typically encroach into Midtown neighborhoods, this zoning type attempts to balance the needs of residents and developers. UV2 would provide depth for larger commercial development while providing buffering mechanisms to help ensure appropriate transitions between neighborhoods and large commercial uses.

Criteria Best applied where assembled lots stretch from an arterial street to a residential street, which would typically provide a depth of 300' in Midtown Tulsa (applied in this manner, the residential street itself would provide one layer of buffering for the neighborhood). UV2 zoning is not recommended where the rear property line of the assembled lots adjoins the side yards of neighboring residential properties. In those cases, the Linear Park buffering option described on page 92 should be implemented.

UV2 zoning may also prove an appropriate solution at arterial intersections, where uses are typically of higher intensities and require greater depth.

UV1 and UV2 zoning can be applied together within the same linear district to create interest, relieve development pressure, and allow room for district-wide shared parking.

Details UV2 zoning will establish a build-to line at the front property line, which will depend on the width of the adjoining sidewalk in the public right of way. (A sidewalk of less than 6' wide, measured from curb to edge of right-of-way, would result in a build-to line that is set back 5' from the front property line.) Otherwise, the build-to line will be the front property line. Restaurants and nightclubs may apply for a variance of up to a 16' setback to allow for front patio seating for their patrons as long as their facade still comes to the newly established building line. Some lots may require view easements and a front setback for public safety on curving streets.

Parking must be located behind or to side of the building (no further forward than the front setback). Refer to page 91 for restrictions on the location of parking within the UV2 development. The main entrance of the building must be oriented to a sidewalk that is adjacent to an arterial street. Drive-thru windows must be restricted to the rear of the building (parking lot side).

Buildings shall be restricted to three-stories. Parking structures shall be restricted to three stories above ground (four levels of parking, including the ground level).

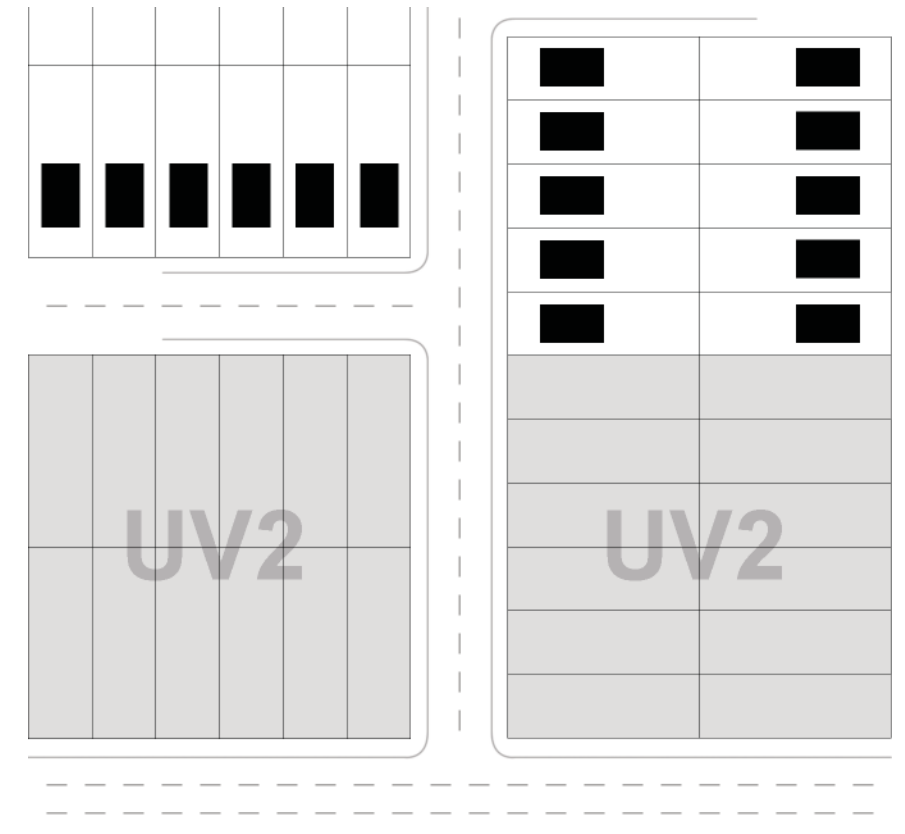

Urban Village Two Zoning. The location on the left is ideal. The location on the right is not recommended.

Appendix 1

UV Zoning Model Guidelines Urban Village Two (UV2)

Details (continued)

In order to balance the needs of neighborhood residents and developers, UV2 zoning creates three linear regions within the depth of the development – commercial, parking, and buffer regions. Uses would be prescribed for each of the regions, so that commercial uses would be directed toward arterial streets and the part of the development closest to the neighborhood would provide adequate buffering.

Commercial region (C)

The commercial region would extend from the property line(s) adjoining an arterial street(s) to a depth of no more than 40% of the total depth of the lot. For lots on the corner of two arterials, the commercial region is permitted to be L-shaped to provide maximum arterial frontage, however the depth of the commercial region must be the same along both legs of the “L” shape and will be calculated as 40% of the shallowest dimension of the lot.

All commercial buildings, including mix-used buildings, should be contained within this region. Parking may be placed within this region, provided it is behind or to the side of the building(s).

Parking region (P)

The parking region would occupy the middle portion of the development, between the commercial region and the buffer region. The parking region may include surface parking or structured parking of no more than three stories above ground (providing four levels of parking, including the ground level). Commercial buildings cannot be built within this region.

Buffer region (B)

The buffer region comprises the rear of the lot, typically adjacent to a residential street, but possibly adjacent to residential property. The buffer region shall be no less than 50’ deep. For developments over 300’ deep, the buffer region shall be no less than 75’ deep. For lots on the corner of two arterials, where the commercial region is permitted to be L-shaped, the buffer region must be designated along one edge of the lot and shall extend the full length of that edge until it adjoins the commercial region.

The construction of commercial buildings and non-residential parking uses are not permitted within this region. No curb cuts providing access to the parking region will be allowed to pass through the buffer region.

Please see the next page for more details of the buffer region.

Appendix 1

UV Zoning Model Guidelines Urban Village Two (UV2)

Details (continued)

The buffer region provides the residential neighborhood with buffering from the commercial and parking aspects of the development in one of two ways – architecture or linear parkland.

Architecture

Within the buffer region, the developer would be permitted to construct single-family homes, townhomes, patio homes, rowhouses, and/or multi-family development (as defined during the neighborhood planning process). Building residential property within the buffer region would preserve the residential character of the adjoining neighborhood – homes across the street would face residential units, not parking.

If multi-family residential properties, rowhouses or townhomes are constructed in the buffer region, then the immediately adjoining 40' of the parking region should be dedicated to resident surface parking, garages, and/or green space(s). Access to the resident parking should be provided through the parking region.

If the UV2-zoned lot contains HP zoned property, the historic district's design guidelines would remain in place, ensuring that the infill development would be compatible with the HP district. It is not suggested that the district's HP boundaries be redrawn. Ideally, the incentive would be to preserve existing historic homes. Further incentives to preserve HP-zoned houses could be built into UV2 zoning (for example, reducing the on-site parking requirement if existing homes are preserved).

If the developer of the commercial development was not interested in building residential properties, they would be permitted to replat the lots and sell them to other developers (with some restrictions on the minimum and maximum lot widths).

Using architecture as the buffer solution is encouraged because it most closely protects the residential character of the adjoining neighborhood, creates desirable housing options, preserves density levels, respects historic districts and has the potential to preserve historic Tulsa homes.

Linear Park

The buffer region would be landscaped as a greenbelt/linear parkland. A screening wall will be erected on the setback line (where the parking region begins). Sidewalks should be preserved or added. The park would provide a landscaping buffer between the neighborhood and the commercial/parking development, as well as a neighborhood amenity. The landscaping will be maintained by the developer. Most appropriately used where a UV2-zoned lot directly adjoins the side yards of residential properties.

Further Study

1. Examine issues of utility easements to the residential properties within the buffer region.
2. Continuing research necessary to ensure gerrymandering of lots would not become an issue.

Appendix 1

UV Zoning Model Guidelines Urban Village Two (UV2)

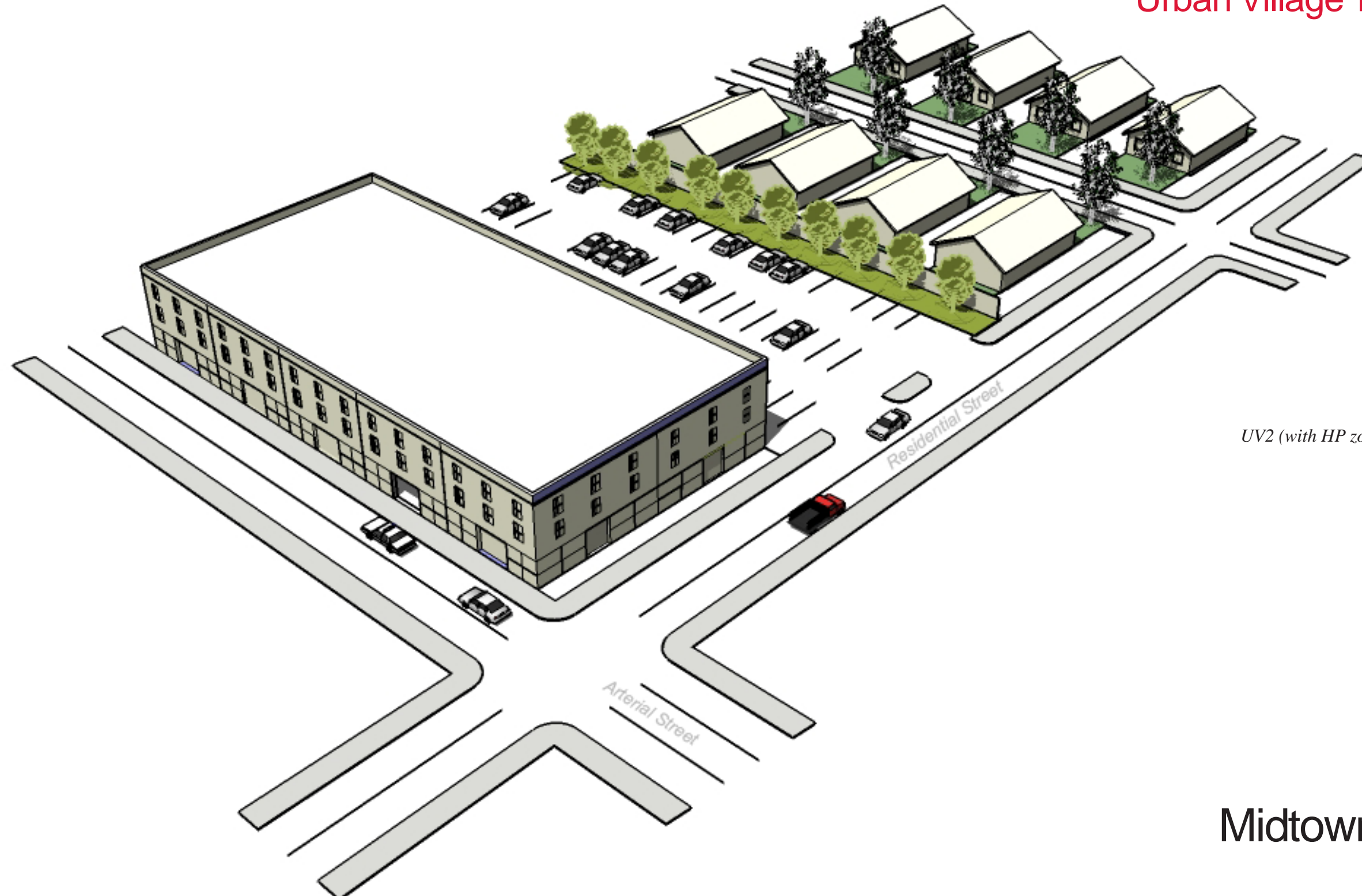

UV2 (with HP zoned homes preserved)



Appendix 1

UV Zoning Model Guidelines Urban Village Two (UV2)

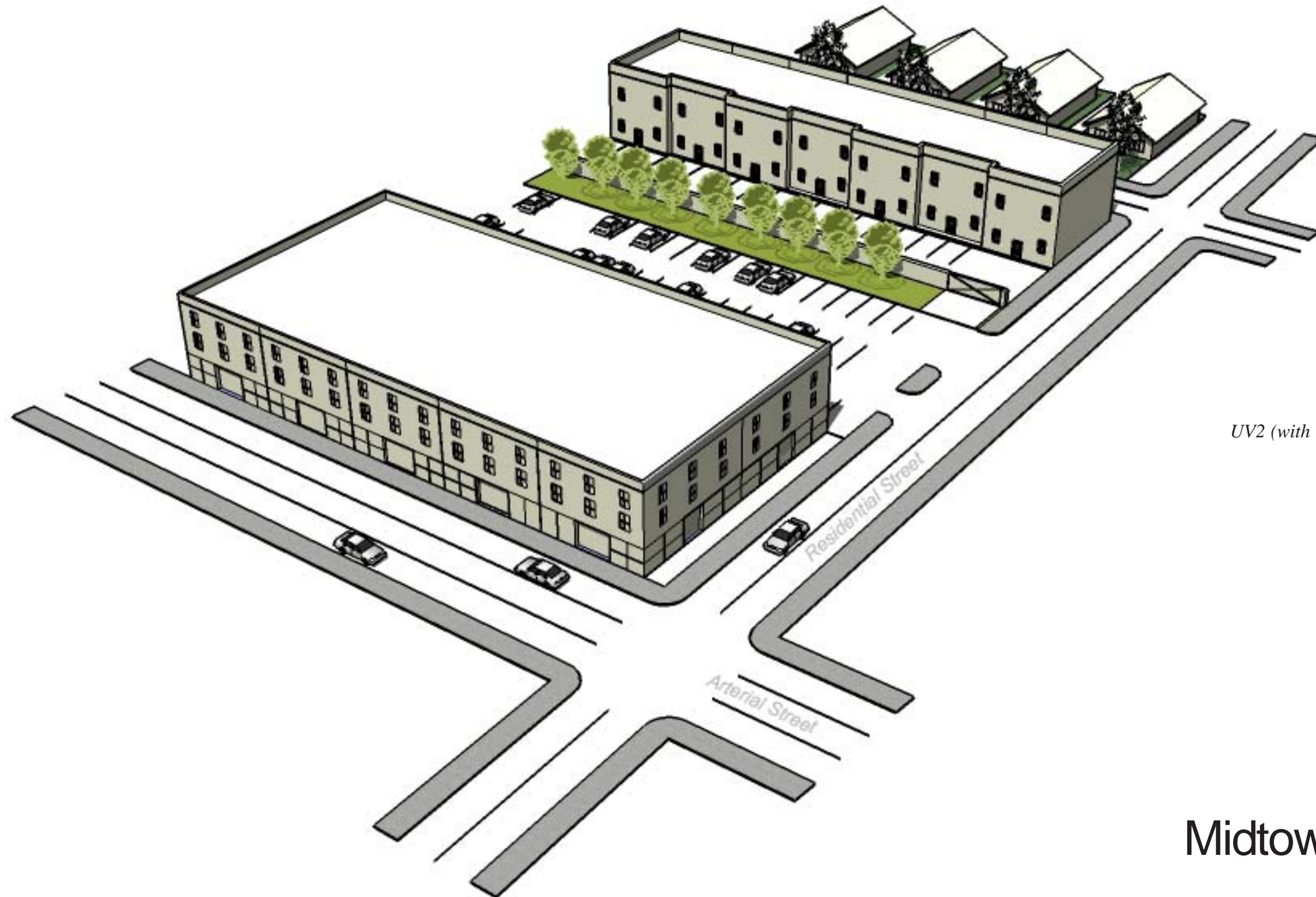

UV2 (with townhomes as buffer)

Appendix 1

UV Zoning Model Guidelines Urban Village Three (UV3)

Purpose	Commercial zoning on sites that are several blocks wide and deep, configured in a “town square” pattern in order to create a destination development.
Criteria	<p>Suited for one corner of arterial intersections, particularly those that abut a physical edge, such as expressways, drainage courses, industrial uses or other non-residential areas.</p> <p>The UV3 zoning type is visualized as providing an economic catalyst for stagnant areas of Tulsa in need of revitalization, possibly where large parcels of land are already assembled and sit vacant. UV3 zoning provides an ideal opportunity for a public/private effort – public funds used to build the UV3’s infrastructure could be leveraged to attract private investment.</p>
Details	<p>Once the acreage was assembled, a new pattern of streets within the footprint of the UV3 development could be built. These streets could take a number of different forms, but the primary purpose would be to frame a town square in the middle of the development. A percentage of the acreage would be set aside for this central open space, around which the commercial and mixed-use buildings would be oriented. The streets surrounding the square would offer angled on-street parking. Surface parking would not be a permitted use on the square. Vehicle speed limits should be no more than 25 miles per hour in order to create a pedestrian-friendly environment. Recommendations 7 and 8 on street improvements and pedestrian amenities (pages 77-79) would be useful in the planning of the UV3 infrastructure.</p> <p>If the City of Tulsa is investing public funds in developing the infrastructure, the town square should be city-owned land and maintained as a public park. If a developer is building the infrastructure, the town square should be made publicly accessible and maintained regularly as a public amenity.</p> <p>Once the infrastructure of the UV3 development has been designed, the UV3 development would be broken down into sections and zoned UV0, UV1 and UV2, depending on their size and proximity to arterials, residential areas, etc. In this manner, UV3 can be considered a collection of Urban Village Zoning types clustered around a central greenspace.</p> <p>In order to create density within the development that would visually frame the town square, developers would be permitted to build one additional story than otherwise permitted under UV1 and/or UV2. Therefore, sections of the UV3 development fronting the town square that are zoned UV1 would permit three-story buildings; UV2-zoned sections fronting the town square would permit four-story buildings and four-story parking structures above ground (five total levels of parking including the ground floor). Sections of the development that do not front the town square would be required to meet standard UV1 and UV2 height restrictions. Sections that are zoned UV0 would be restricted to a maximum of two stories regardless of location within the UV3 development.</p>

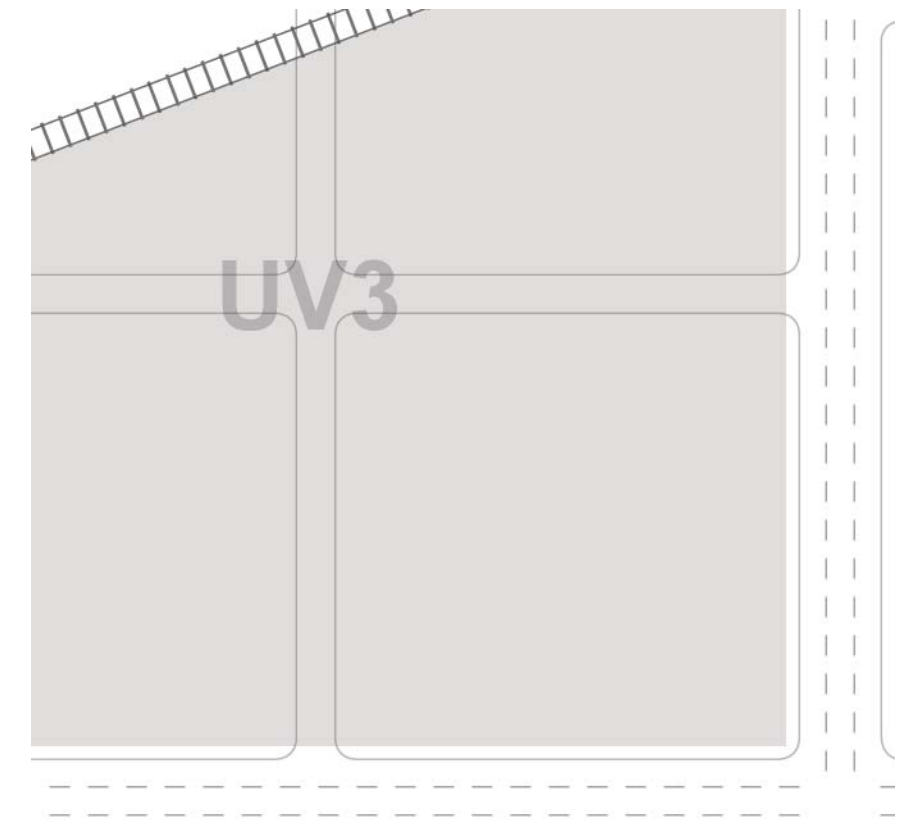

Urban Village Three Zoning. The ideal location would be one corner of an arterial intersection where largely unoccupied land backs up to an edge, such as an expressway or railroad.

Appendix 1

UV Zoning Model Guidelines Urban Village Three (UV3)

Issues

1. Identifying appropriate sites for this zoning type.
2. Assembling the necessary acreage to create an effective development.
3. Sources of public funding if the City of Tulsa were to undertake this type of development.



The University of Oklahoma Urban Design Studio is founded on a three part mission:

- To train urban design professionals through master's degree programs in architecture and urban studies.
- To advance understanding of the city through research and creative activity.
- To engage in community projects benefiting Tulsa and Northeast Oklahoma.

The Urban Design Studio is always looking for promising students and community partners for its endeavors.

For more information, contact us at:

The University of Oklahoma Urban Design Studio
450s East 41st Street
Tulsa, Oklahoma 74135
918.660.3493
sschaefer@ou.edu
<http://tulsagrad.ou.edu/studio>

